

# ***SUPER KIT***

**Student Design Challenge 2021**

PAPERBOARD PACKAGING ALLIANCE

**SUPA TRIO**

Ankita Ghosh, Claudia Natasha, Jessica Vergel

**#HATE  
IS A  
VIRUS**

# MEET THE SUPA TRIO



**Ankita Ghosh**  
Packaging Developer

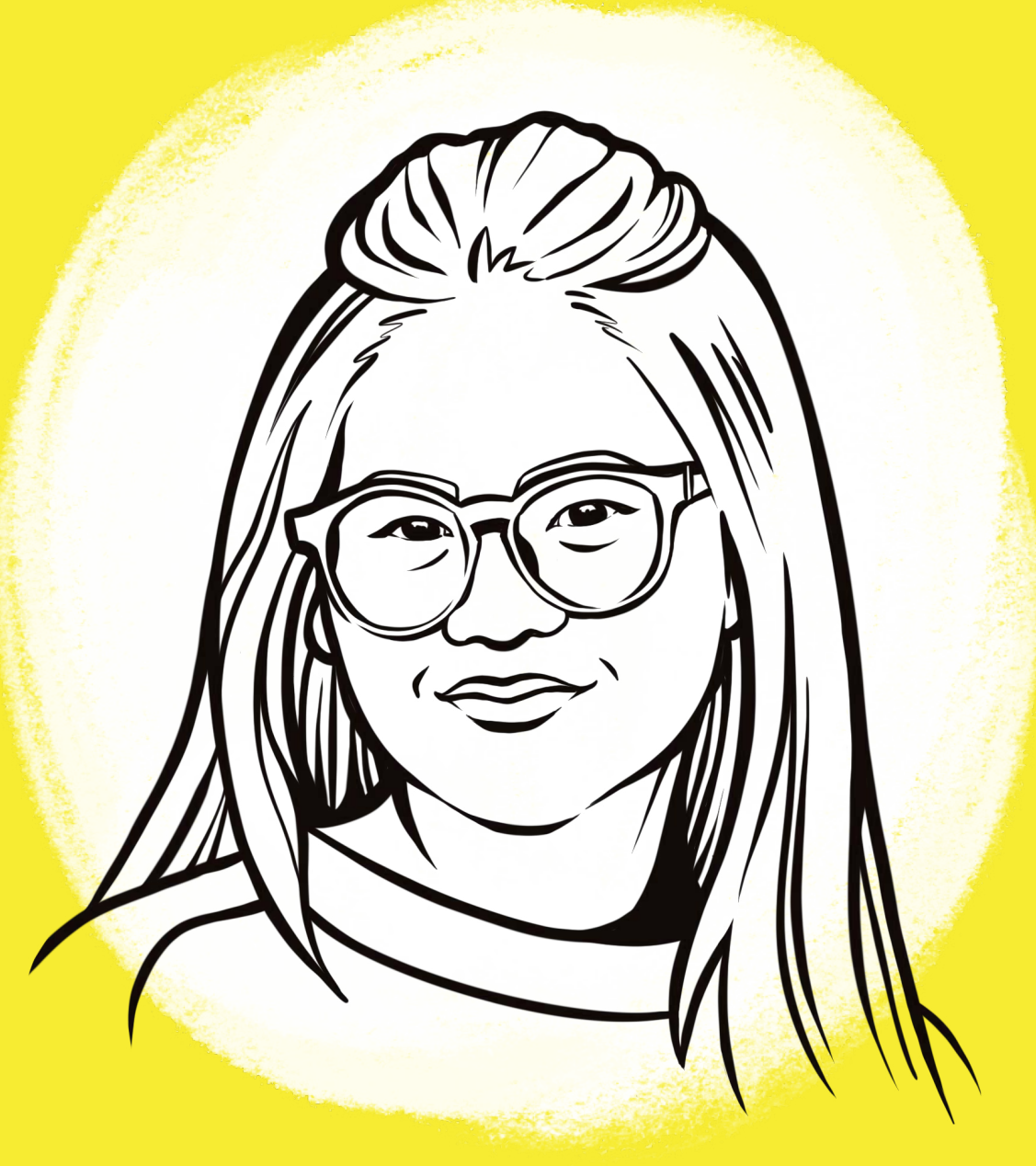

**Claudia Natasha**  
Presentation Designer



**Jessica Vergel**  
Graphic Designer

# CONTENTS

## Marketing Plan

- 05 About Hate Is A Virus
- 06 Executive Summary
- 10 Plan for Program Positioning
- 12 Plan for Program Promotion
- 13 Plan to Appeal to Donors
- 14 Benefits of Design Functionality
- 16 Innovation
- 18 Sustainability
- 19 Plan for Production
- 20 Market Research for Product

## The Super Kit

- 23 The Super Kit Experience
- 27 The Super Qs (conversation cards)
- 29 Design Concept

## Design Process

- 31 Brand Guidelines
- 32 The Shield Structural Process
- 34 The Super Qs Structural Process
- 35 Graphic Process

## Technical

- 38 Prototype
- 40 Dielines
- 43 Plan for Shipping & Receiving

## Brand Activation

- 45 In the Home
- 46 On the Streets
- 47 Online Experience
- 48 Unboxing Video
- 51 Citations

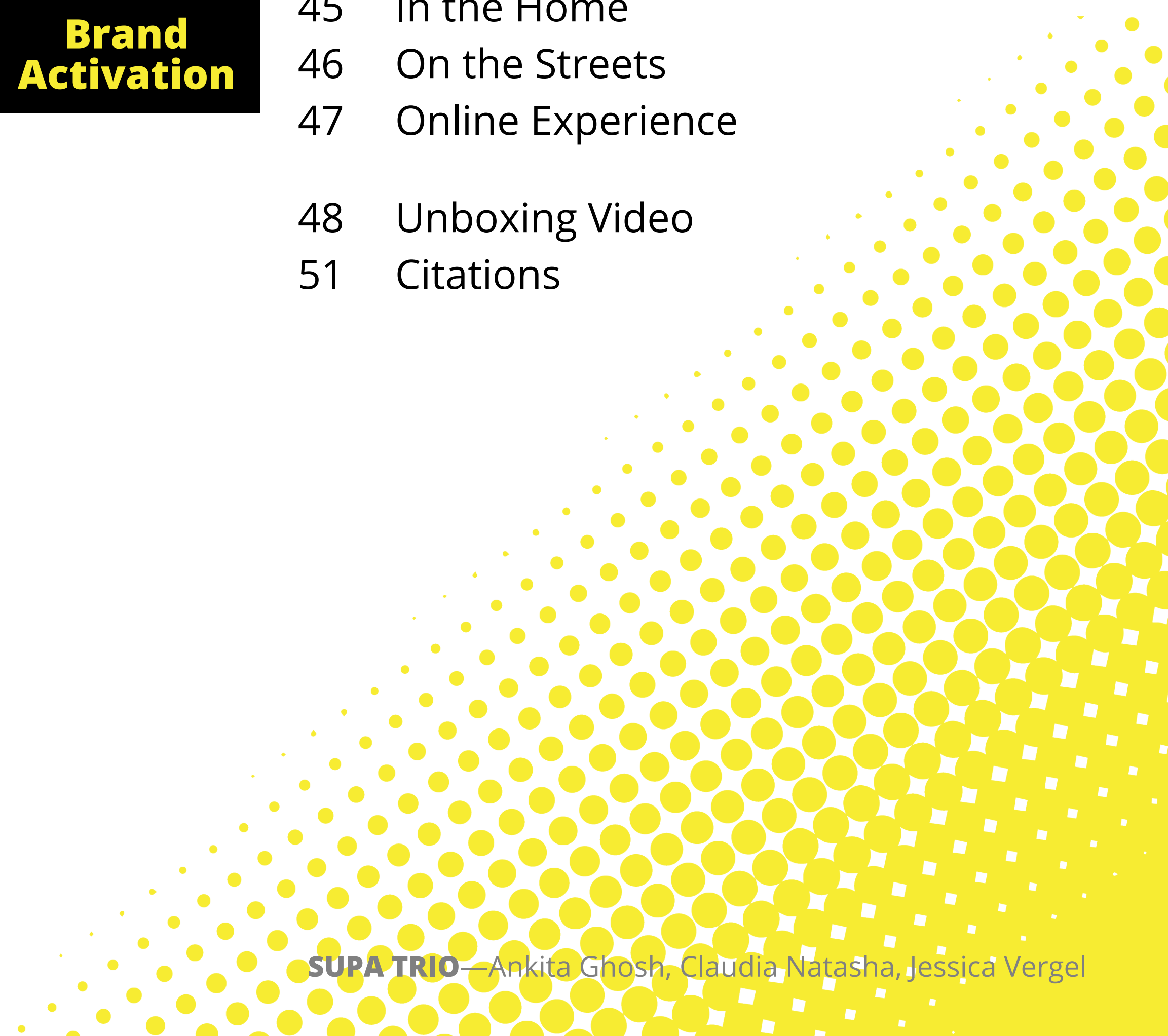

## **PLEASE NOTE**

We have been learning remotely for our Spring 2021 semester. Since we are not on campus and have no access to tools and equipment, our comps are hand-built using materials at hand.

# ABOUT HATE IS A VIRUS

Hate Is A Virus is a community of heroes who are vocal in eradicating hate, specifically racism and violence towards Asian Americans and Pacific Islanders (AAPI). It was founded in April 2020 as a movement that has responded to the spike in hate crimes against AAPI during the COVID-19 pandemic.

They have raised \$30k+ to support essential, BIPOC community organizations across the United States. Their current effort is Community Action Fund—an initiative to raise \$1 million to support local and national “boots-on-the-ground community organizations” that have been fighting against racism and hate.

We are introducing an activity kit for children, called the **Super Kit**, which extends Hate Is A Virus’ mission to the younger generations.

One of the products that the **Super Kit** will house is the **#HATEISAVIRUS Tee**. By wearing this tee shirt, one:

- ★ Raises awareness of the issue of hate
- ★ Promotes and may influence purchases of their products, in which 100% of the profit will support their initiatives.



## EXECUTIVE SUMMARY

Hate Is A Virus launched with three primary goals—Raise Awareness, Educate and Equip, Informed Action—by engaging with people from diverse backgrounds. We can only see them expanding their outreach to audiences from various age groups, especially the younger generations.



## EXECUTIVE SUMMARY (continued)

Unfortunately, racism has even affected children. Although difficult and uncomfortable, parents and guardians wish to initiate the talk with their children about the issue. Despite the plethora of online information, they are looking for practical and appealing resources that offer guidance and direction for them to start the conversation.

Hate Is A Virus will introduce the Super Kit—an activity kit that engages kids in conversation and community action to combat the violence on AAPI communities.

Focusing on their goals, the Super Kit provides parents and guardians with the Super Qs (conversation cards); and children with educational activities, a tee shirt, and a Super Shield.

The Super Qs (conversation cards) guide the entire kit experience, the activities inform and stimulate, the tee shirt raises awareness, and the Super Shield “protects” from racism and hate. As a 100% paper-based activity kit, the Super Kit is proud to help families stand for justice and empower children to fight against hate, while being considerate of the environment.

### The Super Kit fulfills the package requirements

- ★ 100% made out of paperboard
- ★ Dimensions are 8.25" x 6.25" x 2.75"
- ★ Eye-catching, while adhering to the brand style guide
- ★ Contents are fully covered & locking mechanisms ensure security
- ★ Versatility—package protects, educates, entertains and empowers
- ★ Reusability—the entire package is reused for various activities
- ★ Package’s transformation ends the experience with a surprise



**#HATEISAVIRUS Tee**



**Super Qs  
(conversation cards)**



**Asia-Pacific Map**

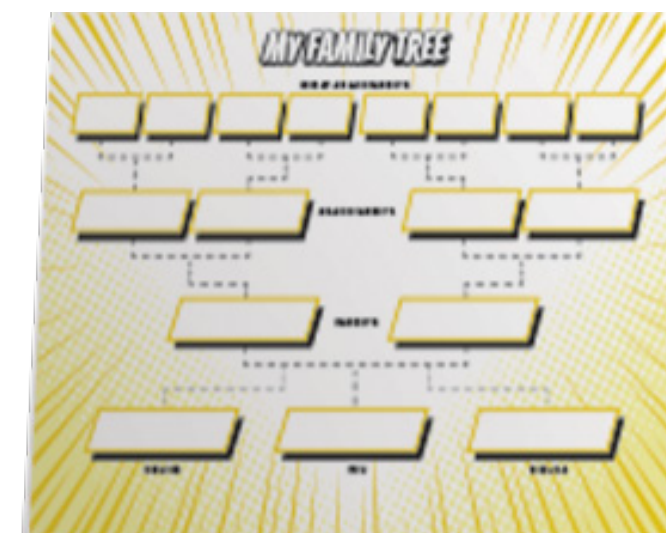

**My Family Tree**



**Super Shield**

# MARKETING PLAN

# PLAN FOR PROGRAM POSITIONING

## Target Audience Portrait

Families who identify with ethnicity/ethnicities from the region of Asia and the Pacific.

### The Children (Primary)

- ★ 5–9 years old
- ★ Curious, independent, and creative
- ★ They are always finding ways to make a difference in the world. At the same time, they sometimes feel overwhelmed and powerless in times of so much uncertainty.

### The Guardians (Secondary)

- ★ 29–45 years old
- ★ Open-minded, inspiring, and hardworking
- ★ Despite their busy lifestyles, their children are their top priorities.



I don't know a lot about race or racism. I hear about it on TV, but I don't know **what to do** about it.

I wish there was an **approachable way** to talk about race, racism, and the anti-Asian violence that is rising in the news.

## PLAN FOR PROGRAM POSITIONING (continued)

### Brand Platform

#### Promise

The Super Kit promises to make AAPI children **feel seen and powerful**.

#### Reason to Believe

A comprehensive educational kit that initiates thoughtful conversation and empowers AAPI children to fight against racism and hate.

#### End Benefits

AAPI children will feel **proud** of their identity and **empowered** to protect and stand up for themselves, their friends and families. In addition, they are encouraged to bring their Super Shield to peaceful protests.

**INFORMED  
ACTIVIST**



**inquisitive**

**creative**

**courageous**

# PLAN FOR PROGRAM PROMOTION

Hate Is A Virus proactively encourages people to show their stand against hate by using the hashtag #HATEISAVIRUS and sharing artworks, self-portraits, or photos of themselves wearing a clothing item with “HATE IS A VIRUS” branding on it.

The Super Kit expands on this initiative in two ways:

## 1 The Super Shield

The children are encouraged to share the decorated Super Shield with #HATEISAVIRUS to get featured on the Instagram page. The following actions will facilitate the outreach of the kit to a broader audience.

## 2 #HATEISAVIRUS Tee

Wearing this tee shirt may direct people to Hate Is A Virus’ shop and influence them to purchase their products.



## PLAN TO APPEAL TO DONORS

Hate Is A Virus will send **direct mail** to potential donors to make donations online for the execution of the Super Kit.

Using paper, direct mail has a more personal touch compared to electronic mail, which will foster **empathy** and entice potential donors to give donations. Simultaneously, it can guide potential donors to Hate Is A Virus' **online touchpoints**, by providing them with QR codes.



# BENEFITS OF DESIGN FUNCTIONALITY

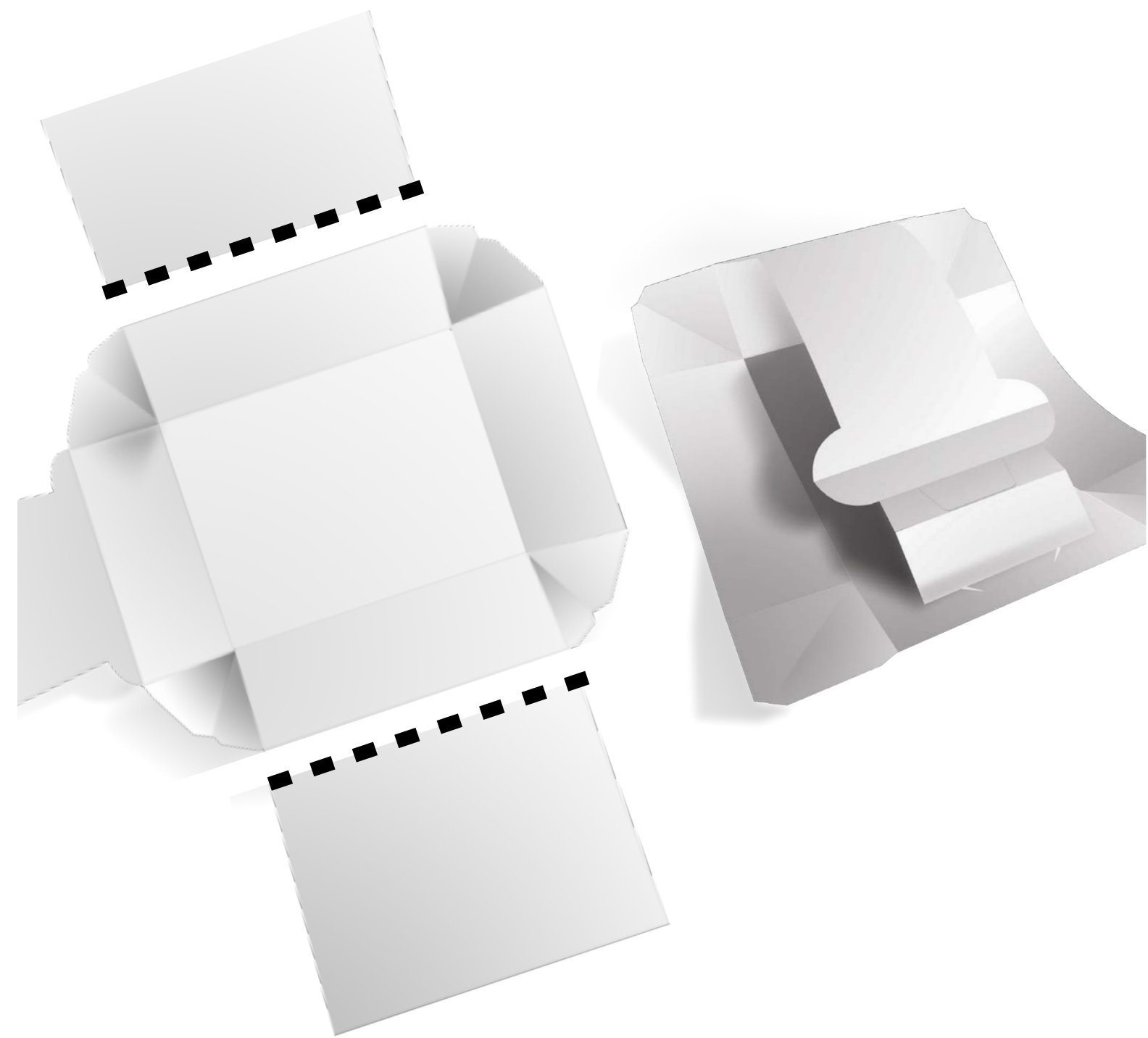

## Symbolism

- ★ Tearing off perforated sections symbolizes the **dismantling of racism**
- ★ Assembling the Super Shield symbolizes **community building**

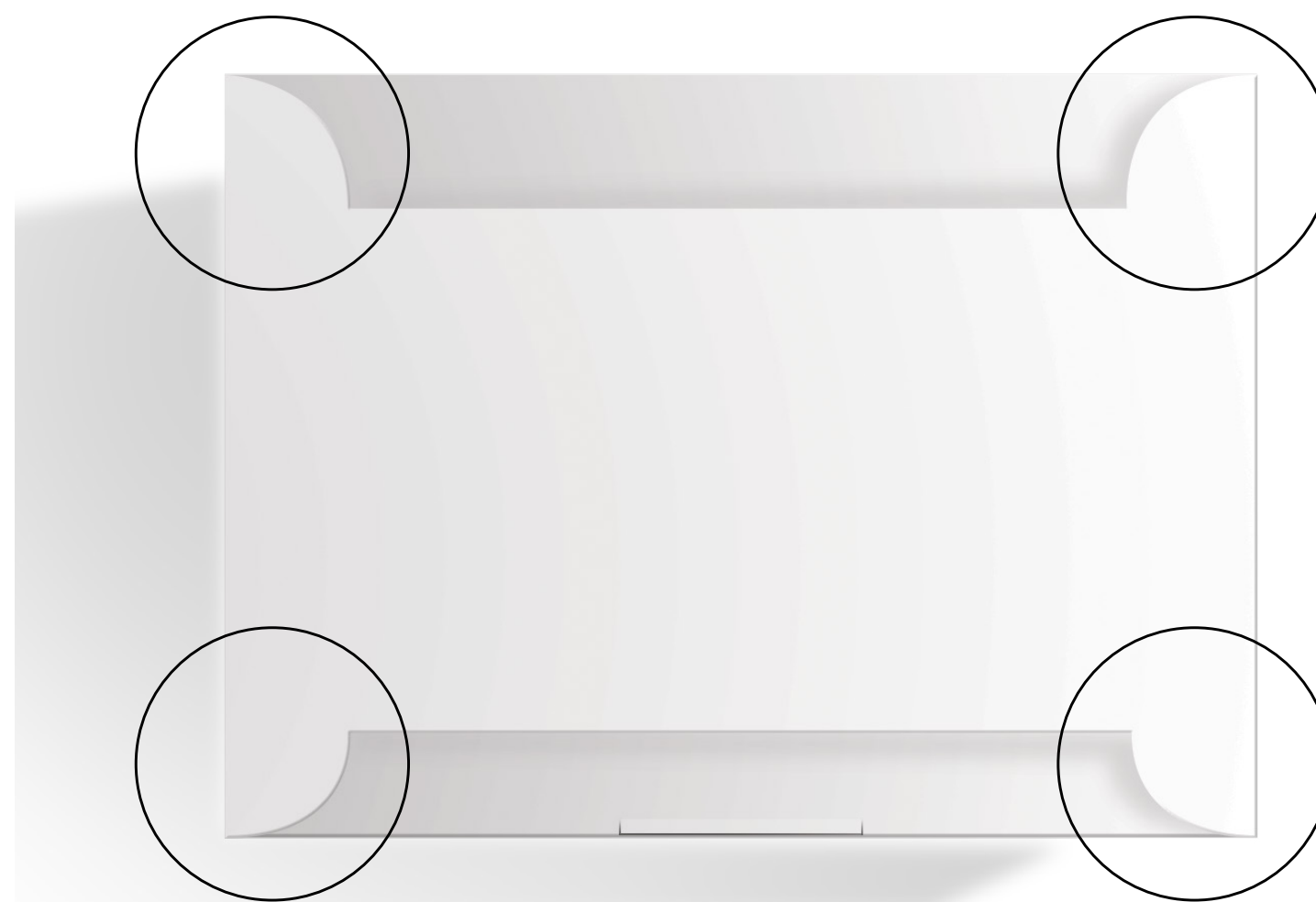

## Durability

**Radius** on each corner improves the integrity of the strap when carried

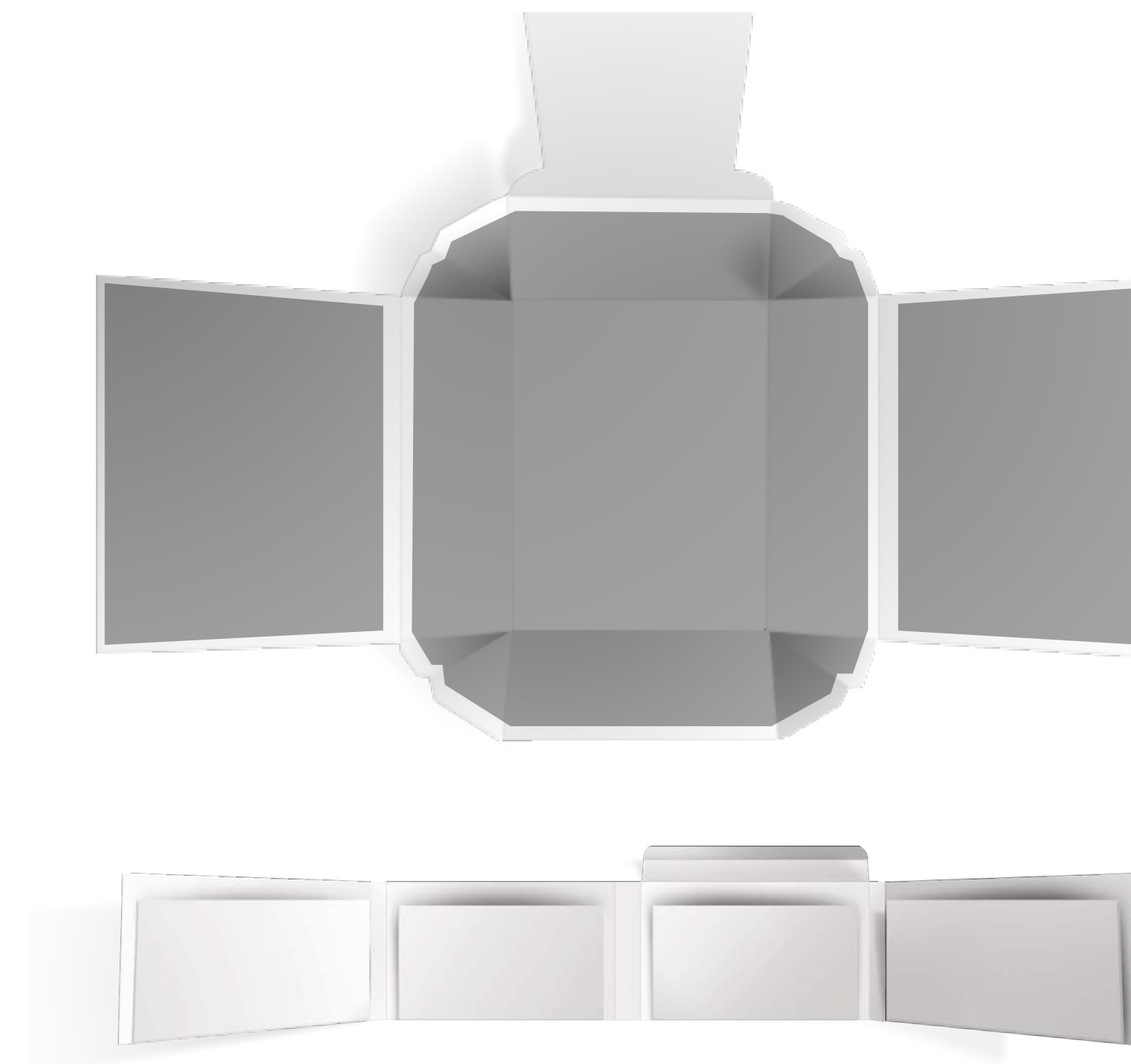

## Reusability & Versatility

- ★ Educational activities are printed on the inside of the package to allow the entire package to have a **second-use**
- ★ The Super Qs (conversation cards) wallet organizes the cards by topic & prevents them from scattering

## BENEFITS OF DESIGN FUNCTIONALITY (continued)



### Adhesive-free

The main structure is 100% adhesive-free, which makes it **eco-friendly** & promotes **easier assembly**

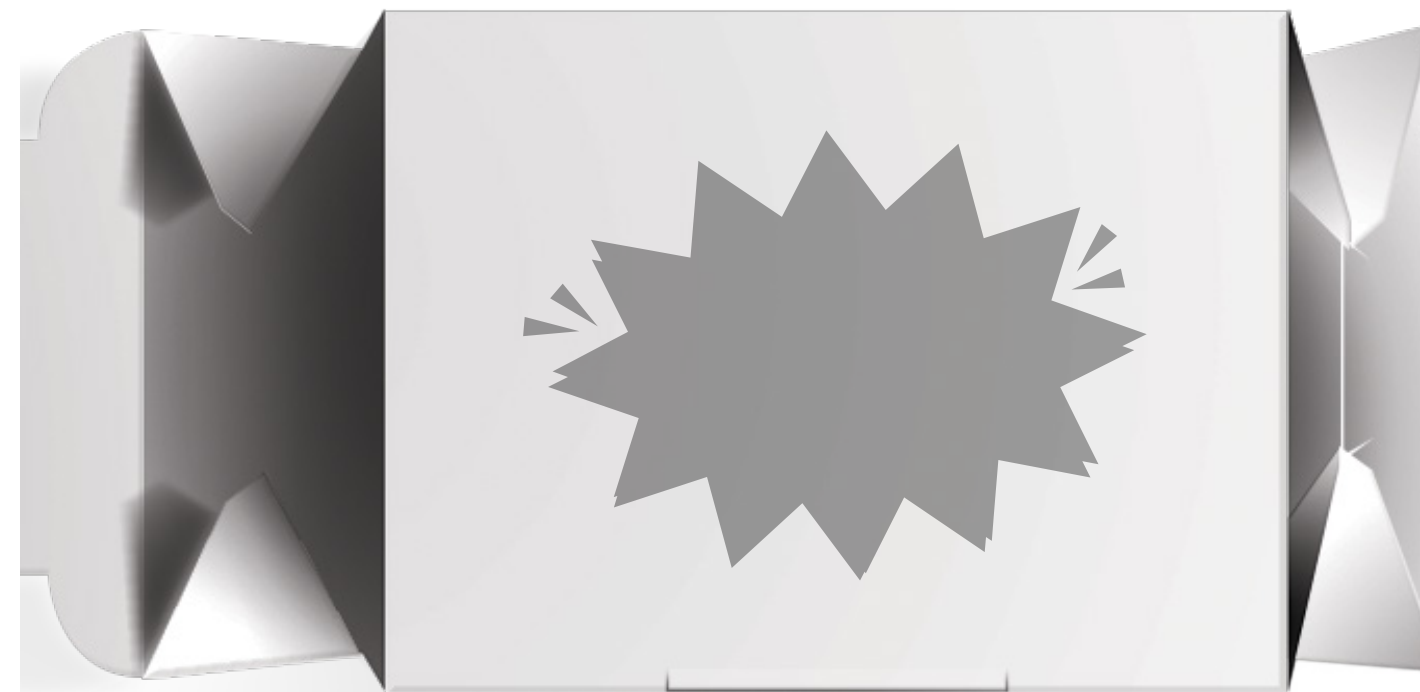

### Unboxing

- ★ Children are greeted with a friendly welcome message
- ★ Opening multiple panels before the contents' reveal **generates excitement**



### End Surprise

The package's **transformation** into the Super Shield concludes the experience in a surprising way

# INNOVATION

## Modification of an Existing Dieline

The shield concept was inspired by an existing carton. Major modifications include:

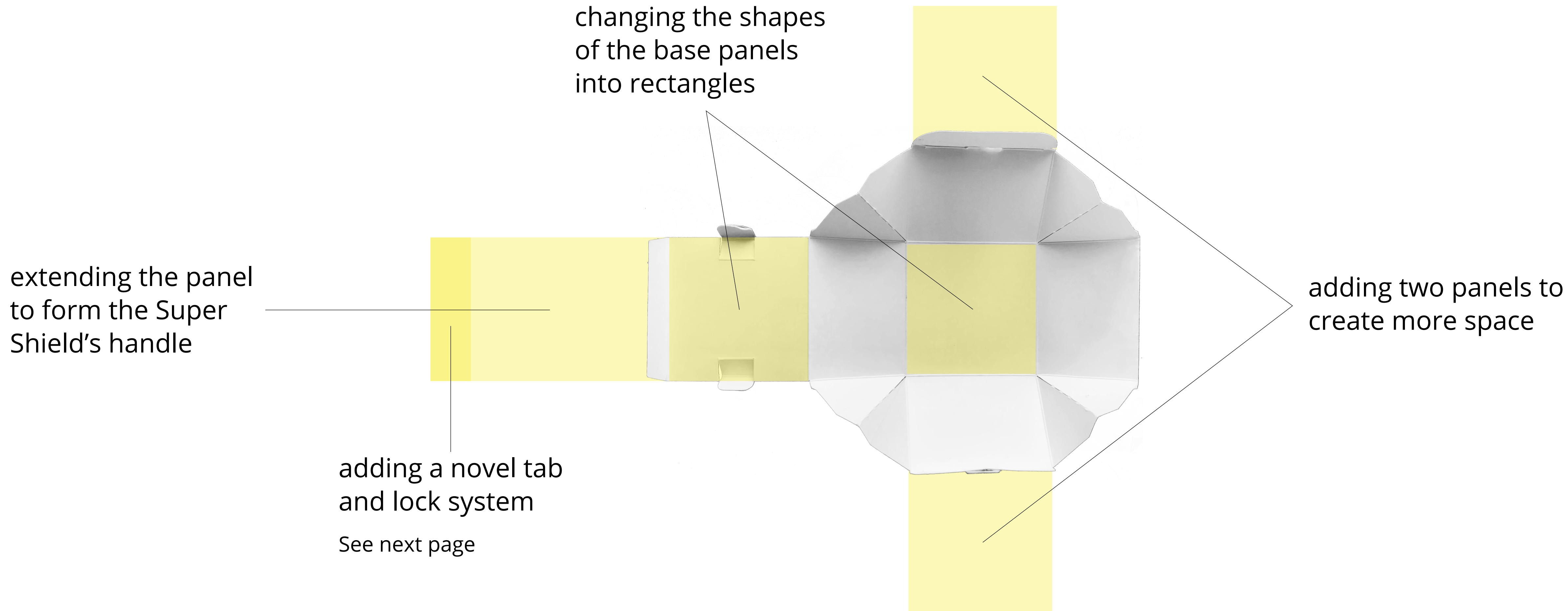

# INNOVATION (continued)

## Novel Tab and Lock System

Two tabs are employed to secure at the same location, but each for a different purpose. See page 48 (Unboxing Video).



This is **Tab 1**

Outside of the strap

This is **Tab 2**

Inside of the strap

**Tab 1** locks the package

**Tab 2** locks the shield's strap

This is the box converted into the shield

# SUSTAINABILITY

## 100% Paperboard

The Super Kit is recyclable and made out of post-consumer recycled paperboard

## Reusability & Versatility

- ★ Educational activities are printed on the inside of the package to allow the entire package to have a second-use
- ★ The Super Qs (conversation cards) wallet organizes the cards by topic & prevents them from scattering

## Adhesive-free

The main structure is 100% adhesive-free, which makes it eco-friendly and promotes easier assembly

## Sustainable Production

- ★ Made from a renewable resource and is recyclable
- ★ Printing using vegetable-based inks



## PLAN FOR PRODUCTION

### Substrate Data

- ★ **Grade:** Solid Bleached Sulphate (SBS), Everest™ Folding Carton Board
  - Currently, SBS is more affordable than SUS and CRB, due to less demand in the market
  - Double bleaching process allows for higher-quality graphics
- ★ **Sheet Size:** 28" x 40"
- ★ **Caliper:** 22 pt
- ★ **Tear:** Higher tear strength
- ★ **Coating:** Coating Two Sides (C2S) with Standard Acrylic
  - Thin layer of kaolin clay & titanium dioxide improves color, smoothness & printing receptivity
  - Standard Acrylic coating is compatible with markers and pens.
- ★ **Grain Direction:** Long grain

### Ink & Printing Data

- ★ **CMYK 4-color process + 1 spot color** (PANTONE CMYK Coated: P 166-8 C)
- ★ **Ink:** vegetable-based ink
  - Biodegradable and requires less ink because of high-vibrancy
- ★ **Printing:** Perfecting Press (Single pass)
  - Increases production availability time
  - Lower ink consumption with faster printing speeds



# MARKET RESEARCH FOR PRODUCT

## Organization Competitors

- ★ **Asian American LEAD (AALEAD)**  
supports low-income AAPI youth
- ★ **Stop AAPI Hate**  
acts as a reporting center
- ★ **Asian Hall of Fame**  
recognizes Asians' achievements
- ★ **Asian Mental Health Collective**  
provides mental health services to Asians
- ★ **Asian Americans Advancing Justice**  
fights for Asian Americans' civil rights

**Hate Is A Virus** was chosen because of their **creative** approach in bringing the community together through art, and their **strong branding**.

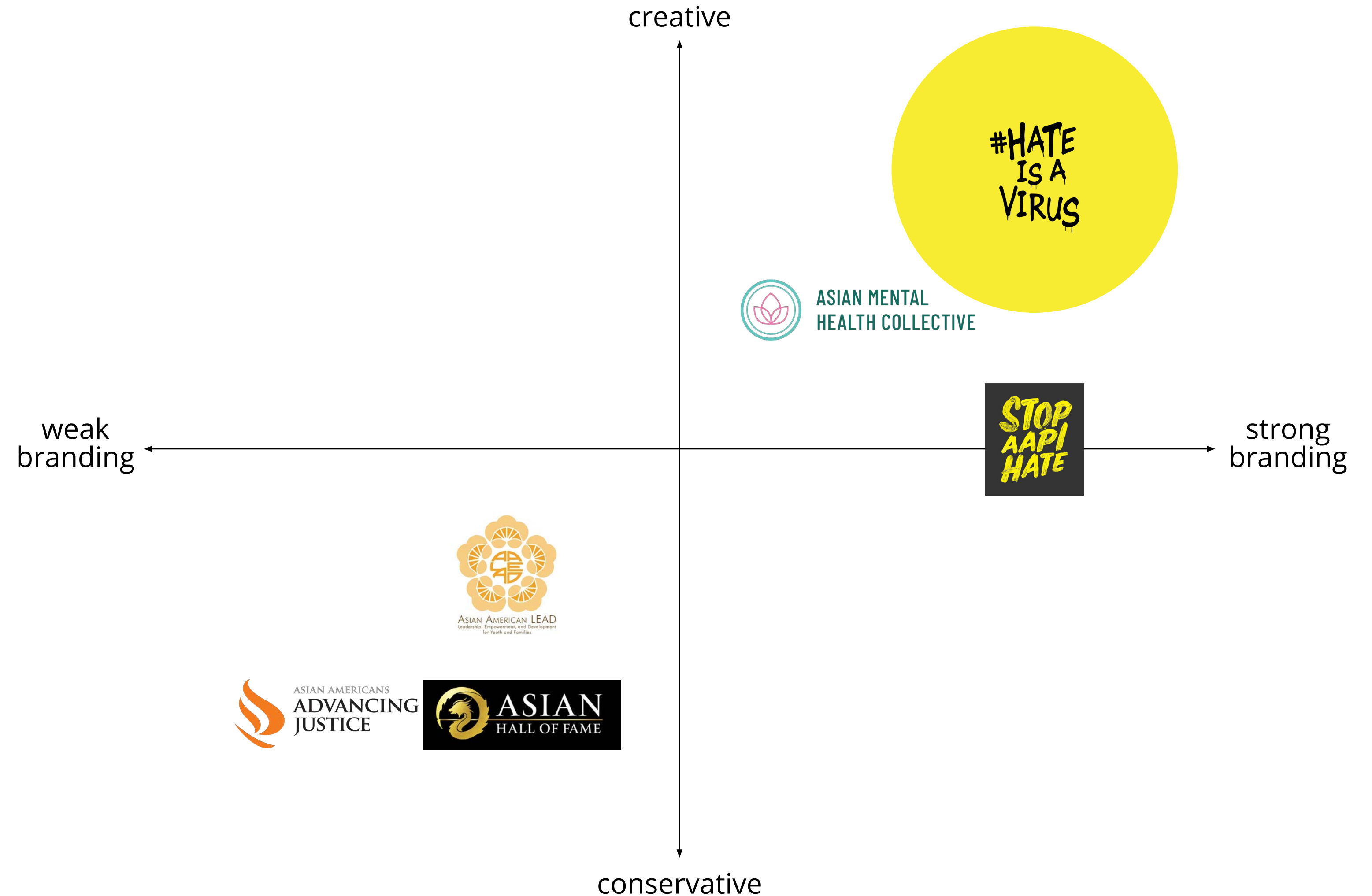

# MARKET RESEARCH FOR PRODUCT (continued)

## Product Competitors

- ★ **Little Traveler's Library**  
 multilingual books that introduces children to different cultures & places
- ★ **In KidZ**  
 curated boxes of products that educates children about diversity
- ★ **ByUs Box**  
 provides guides to families in becoming anti-racist and inclusive
- ★ **Atlas Book Club**  
 delivers culturally diverse books & other curated items for children
- ★ **A Kids Book About**  
 provides children with books about complex topics

We saw an opportunity to introduce the **Super Kit** which would provide a **serious** tone and **active engagement** for an overlooked target audience.



# THE SUPER KIT

# THE SUPER KIT EXPERIENCE



## STEP 1

The child unboxes the Super Kit.



## STEP 2

The welcome message greets and...

# THE SUPER KIT EXPERIENCE (continued)



... informs the child about the Super Kit.

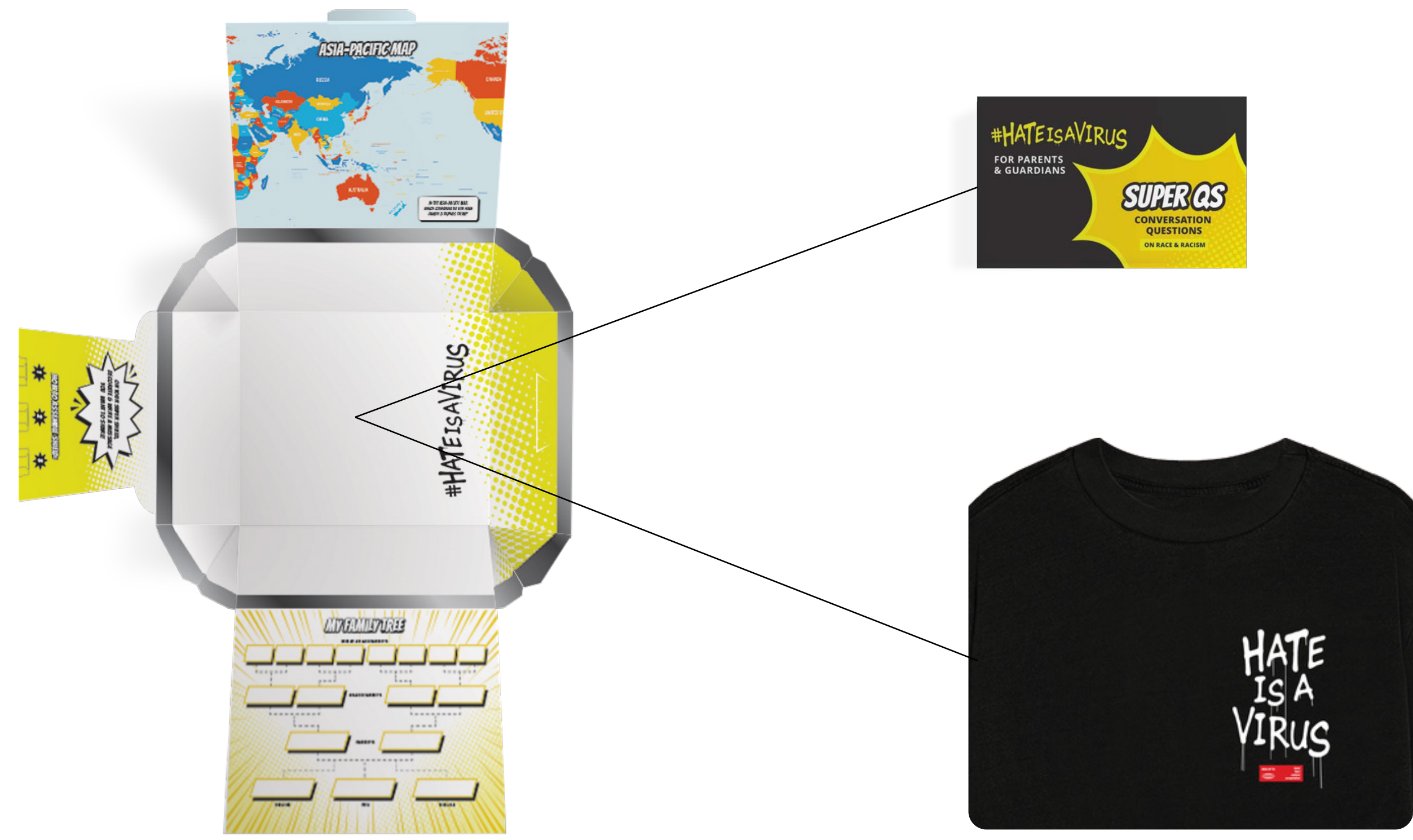

## STEP 3

The Super Qs (conversation cards) are handed to parents and the #HATEISAVIRUS Tee is removed.

# THE SUPER KIT EXPERIENCE (continued)

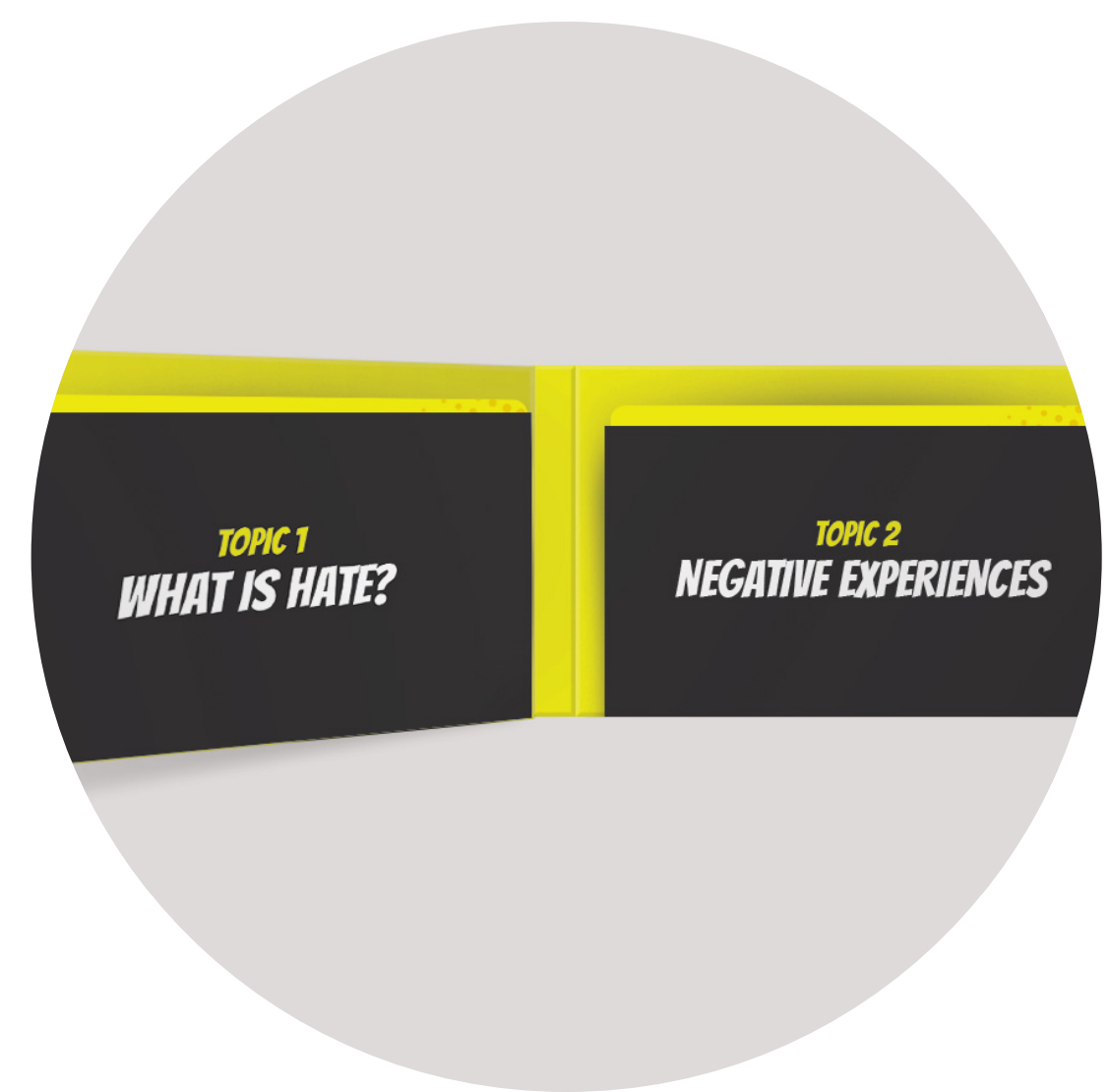

## STEP 4

The guardian starts an open conversation about race and racism with their child guided by questions from **TOPIC 1** & **TOPIC 2**



## STEP 5

The guardian talks about **TOPIC 3**. The Asia-Pacific Map and My Family Tree are torn off. The child follows instructions on the map and fills out My Family Tree.



## STEP 6

The last topic is a call to action. The guardian talks about **TOPIC 4**. Then, the child decorates their Super Shield which becomes a powerful protest sign.

## THE SUPER KIT EXPERIENCE (continued)



### STEP 7

Following the instructions on the strap, the Super Shield is assembled.



### STEP 8

With permission, the guardian or the child shares a photo of the decorated Super Shield to social media channels using #HATEISAVIRUS.



### STEP 9

Accompanied by the guardian, the child wears the #HATEISAVIRUS Tee and brings the Super Shield to peaceful protests.

# THE SUPER QS (conversation cards)

The Super Qs are 20 conversation cards (organized by four topics) that facilitate guardians in initiating a conversation with their child about race and racism—since it is difficult, uncomfortable and many of them do not know where to start.

## Benefits:

- ★ Helps guardians initiate “the talk” in a casual and non-intimidating way
- ★ Makes guardians’ involvement essential for the entire Super Kit experience, unlike product competitors
- ★ The wallet organizes the cards by topic
- ★ The wallet protects the cards from damage and prevents from scattering
- ★ Pocket-sized and easy to be carried

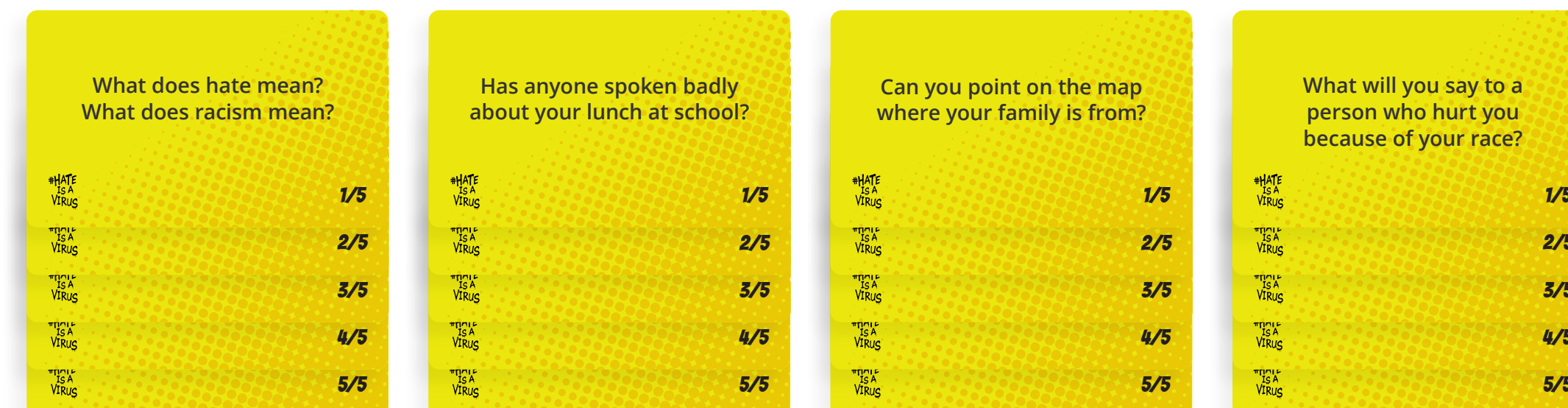

# THE SUPER QS (conversation cards) (continued)

## TOPIC 1 WHAT IS HATE?

What does hate mean?  
What does racism mean?  
#HATE IS A VIRUS 1/5

Why do you think  
hate is a virus?  
#HATE IS A VIRUS 2/5

Do you think skin color  
makes a person  
good or bad?  
#HATE IS A VIRUS 3/5

What do you think about  
having friends who are  
unique & different?  
#HATE IS A VIRUS 4/5

Do you think hating  
somebody makes you a  
better person?  
#HATE IS A VIRUS 5/5

## TOPIC 2 NEGATIVE EXPERIENCES

Has anyone spoken badly  
about your lunch at school?  
#HATE IS A VIRUS 1/5

Has anyone ever mocked  
you because of the color  
of your skin?  
#HATE IS A VIRUS 2/5

Have you ever been called a  
name that you did not like?  
#HATE IS A VIRUS 3/5

Do you want to hear a  
story about Mom & Dad  
overcoming challenges?  
#HATE IS A VIRUS 4/5

What have you heard about  
what has been happening  
to Asian Americans?  
#HATE IS A VIRUS 5/5

## TOPIC 3 MY HERITAGE

Can you point on the map  
where your family is from?  
#HATE IS A VIRUS 1/5

What is your favorite  
food from your country  
or countries?  
#HATE IS A VIRUS 2/5

Can you mention one  
tradition from your country  
or countries?  
#HATE IS A VIRUS 3/5

Do you know how to  
say "hello" in your  
mother language?  
#HATE IS A VIRUS 4/5

What do you know about  
Asia & the Pacific Islands?  
#HATE IS A VIRUS 5/5

## TOPIC 4 LET'S FIGHT HATE!

What will you say to a  
person who hurt you  
because of your race?  
#HATE IS A VIRUS 1/5

What will you do if you see  
your friend hurt because of  
their race?  
#HATE IS A VIRUS 2/5

What shouldn't you do if  
someone say bad things  
about you?  
#HATE IS A VIRUS 3/5

What can you & I can do to  
fight hate & racism?  
#HATE IS A VIRUS 4/5

What change do you want to  
see in our community about  
hate & racism?  
#HATE IS A VIRUS 5/5

## DESIGN CONCEPT

The Super Kit embodies Hate Is A Virus' expressive and bravado spirit. Taking on the Super Shield as a symbol of protection and the tee shirt as a combat uniform, children are empowered in **fighting against racism and hate.**

Contents support the Super Kit concept:

- ★ **#HATEISAVIRUS Tee** propels children to raise awareness and to show their support for Hate Is A Virus.
- ★ The **Super Shield** encourages children to creatively express their thoughts and feelings about race and racism.
- ★ The **Super Qs** (conversation cards) vitalizes guardians' involvement and guides children throughout the entire Super Kit experience.
- ★ **Asia-Pacific Map** and **My Family Tree** activities educate children on their identities from a global and local perspective.



# DESIGN PROCESS

# BRAND GUIDELINES

PRIMARY MARK IN BLACK

SECONDARY MARK IN BLACK

#HATE  
IS A  
VIRUS

#HATEISAVIRUS

## COLOR

<p>HEX #231F20 PMS 166-8 C</p> <p>R 235 G 231 B 22</p> <p>C 11% M 0% Y 100% K 0%</p>	<p>HEX #333132</p> <p>R 51 G 49 B 50</p> <p>C 0% M 0% Y 0% K 95%</p>	<p>HEX #E4C944</p> <p>R 228 G 201 B 68</p> <p>C 3% M 11% Y 100% K 7%</p>	<p>HEX #FFFFFF</p> <p>R 255 G 255 B 255</p> <p>C 0% M 0% Y 0% K 0%</p>
--	--	--	--

## PATTERNS & TEXTURES

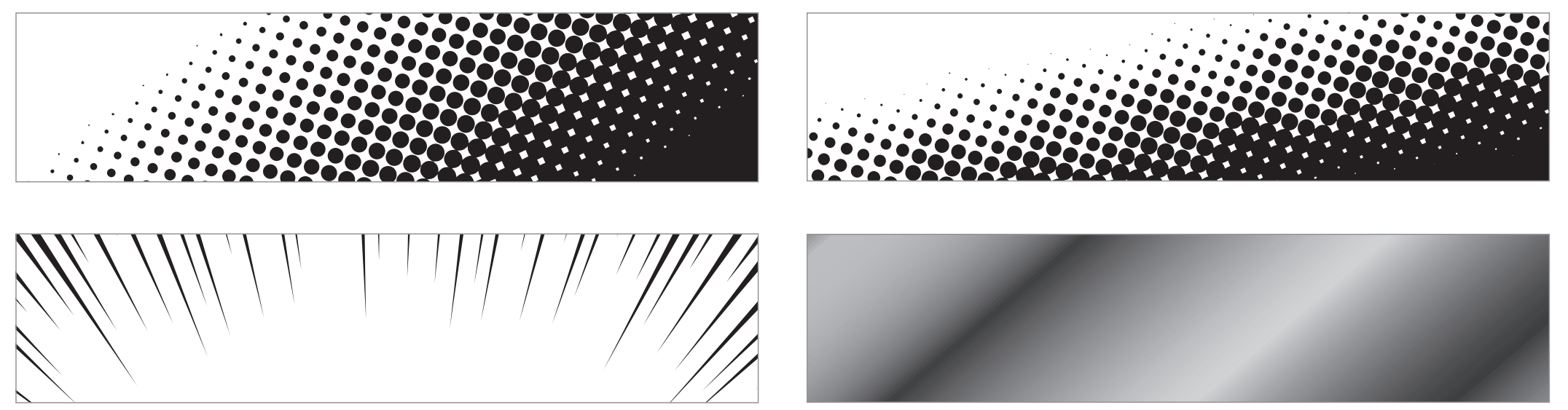

TYPOGRAPHY, HEADING & BODY COPY

## BANGERS - REGULAR

ABCDEFGHIJKLMNOPQRSTUVWXYZ  
XYZÄÄÖÖ0123456789\*!/?&#\$

TYPOGRAPHY, SECONDARY BODY COPY

## OPEN SANS - BOLD

AaBbCcDdEeFfGgHhIijjKkLlMmNnOoPpQqRrSs  
TtUuVvWwXxYyZzÅåÄäÖö0123456789\*!/?&#\$

## OPEN SANS - EXTRA BOLD

AaBbCcDdEeFfGgHhIijjKkLlMmNnOoPpQqRrSs  
TtUuVvWwXxYyZzÅåÄäÖö0123456789\*!/?&#\$

## SECONDARY GRAPHICS

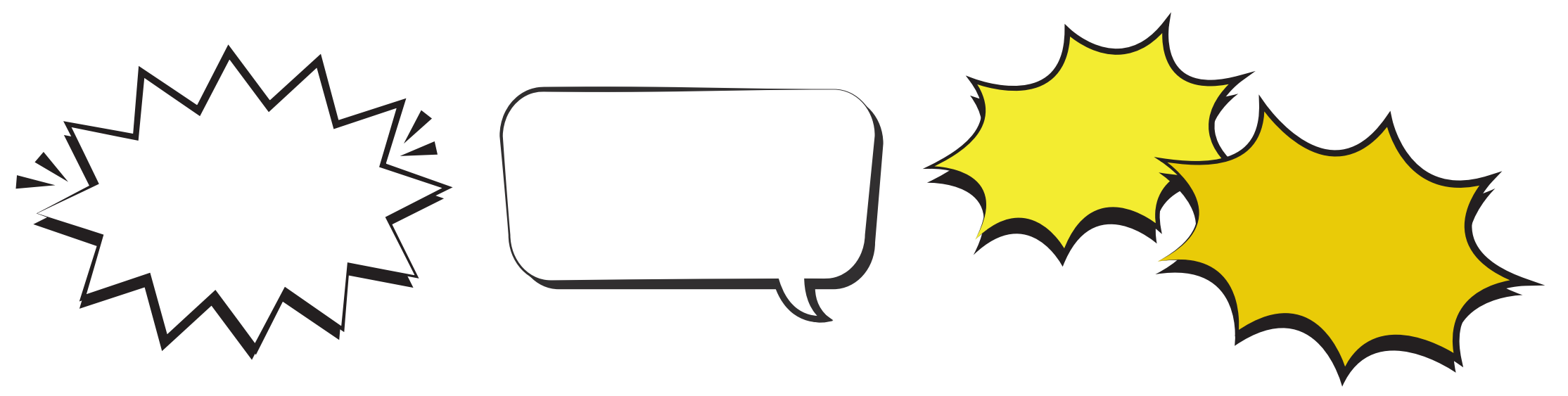

# THE SHIELD STRUCTURAL PROCESS

## Phase 1

twin hinged straight tuck

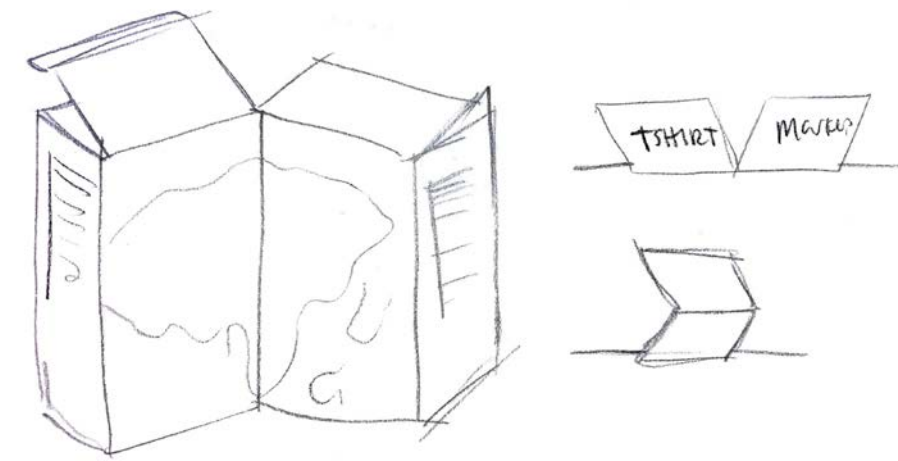

shield

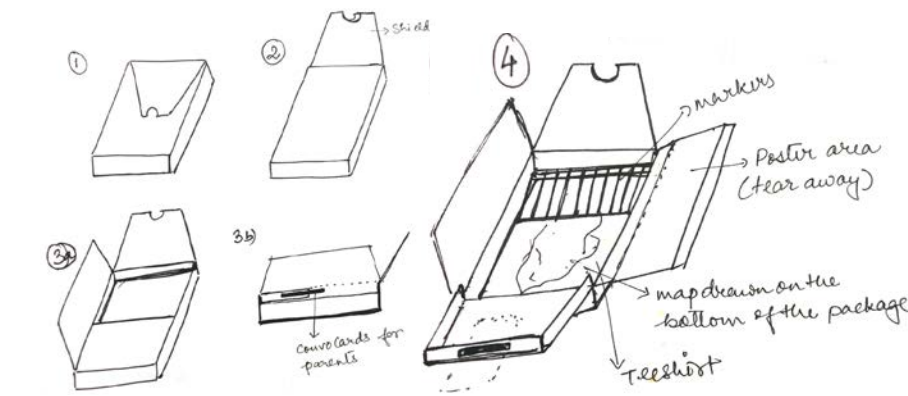

backpack

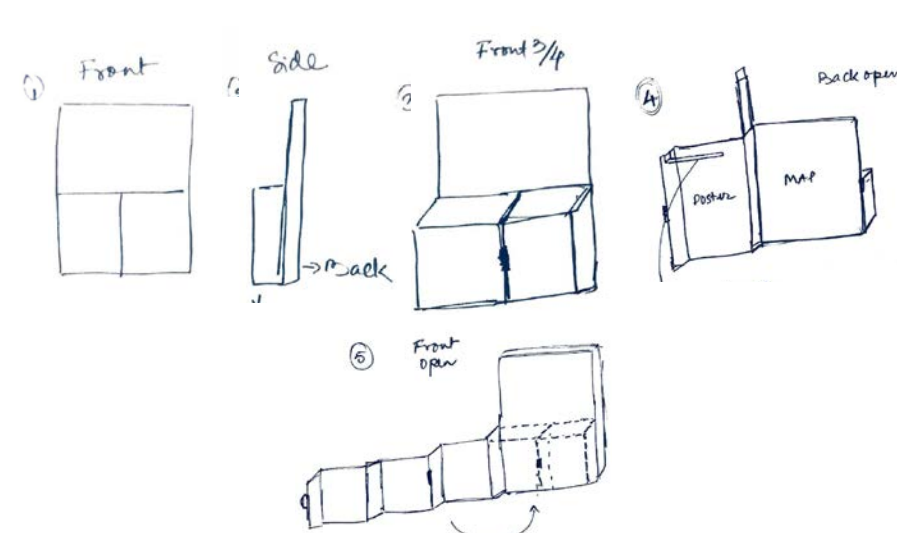

wall hanging

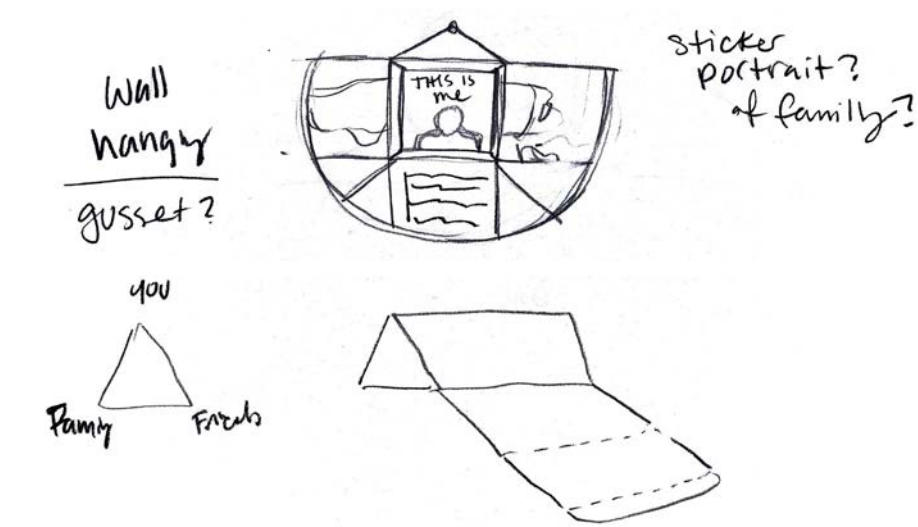

letter

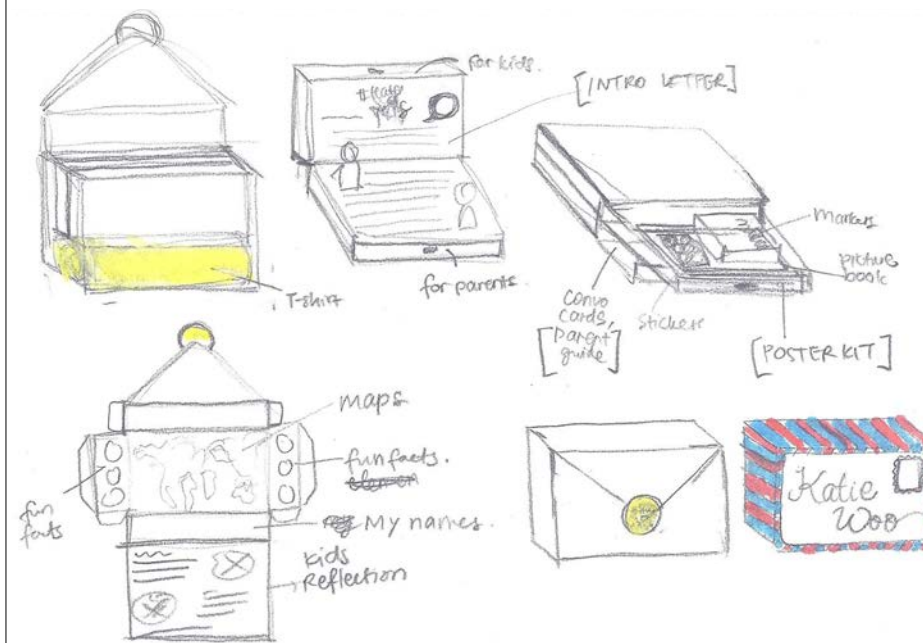

PPE kit

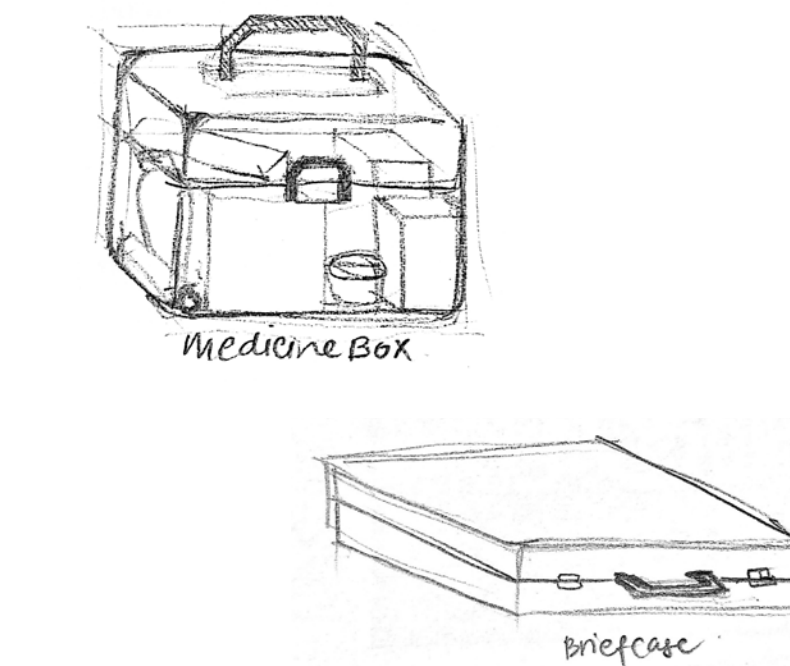

## Phase 2

shield + wall hanging

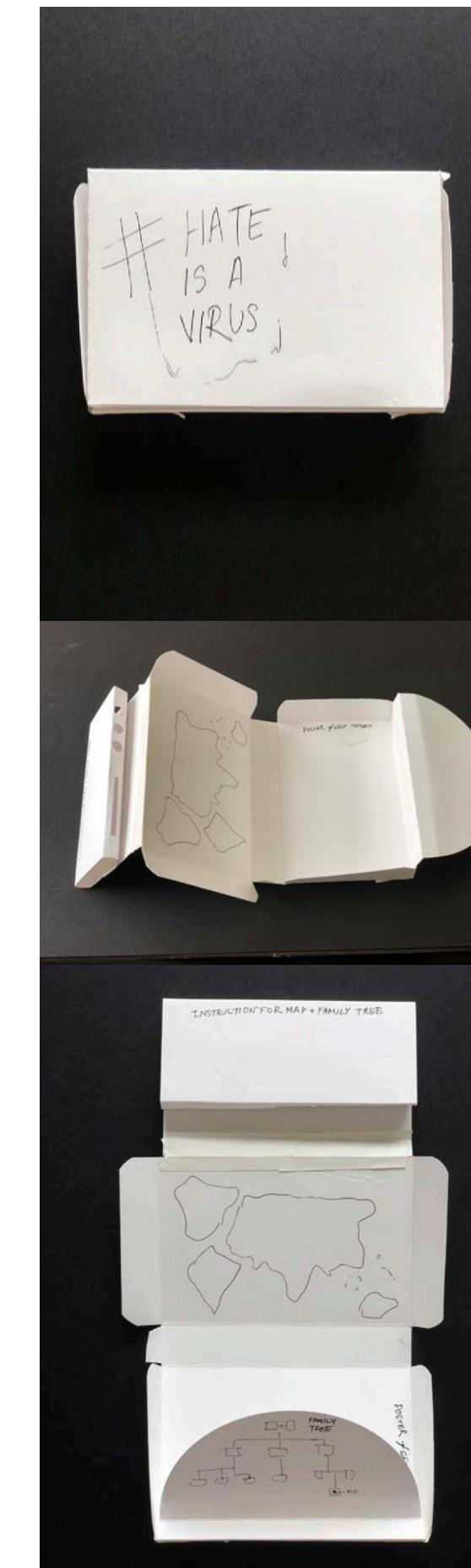

shield+letter

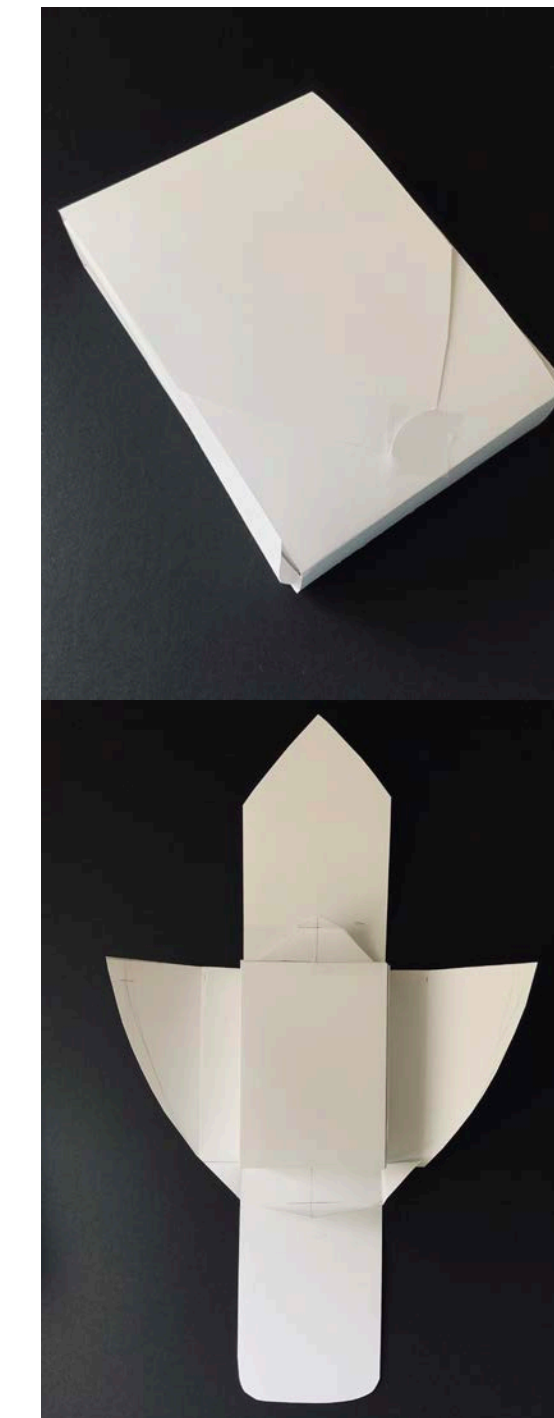

shield

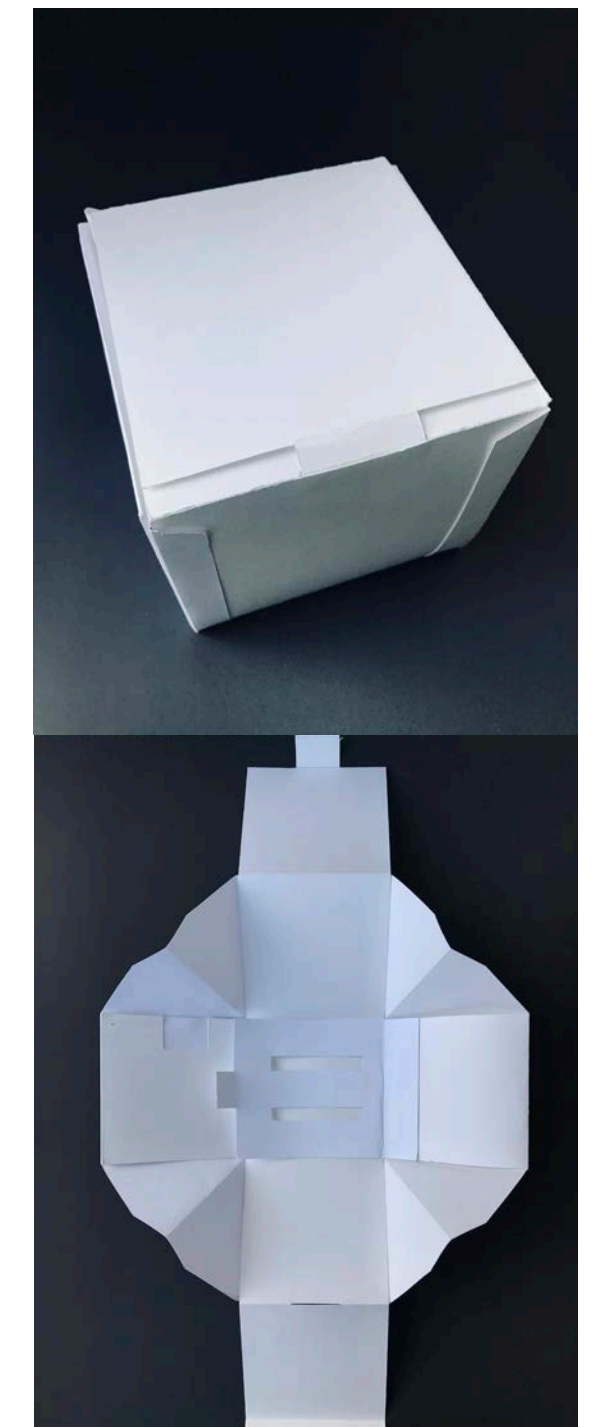

# THE SHIELD STRUCTURAL PROCESS (continued)

## Phase 3



*Super Kit (outer & inner carton)*

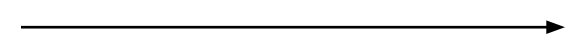

Reduced two straps to a single strap and added radius on each corner to minimize the risk of tear and provide additional support

## Phase 4

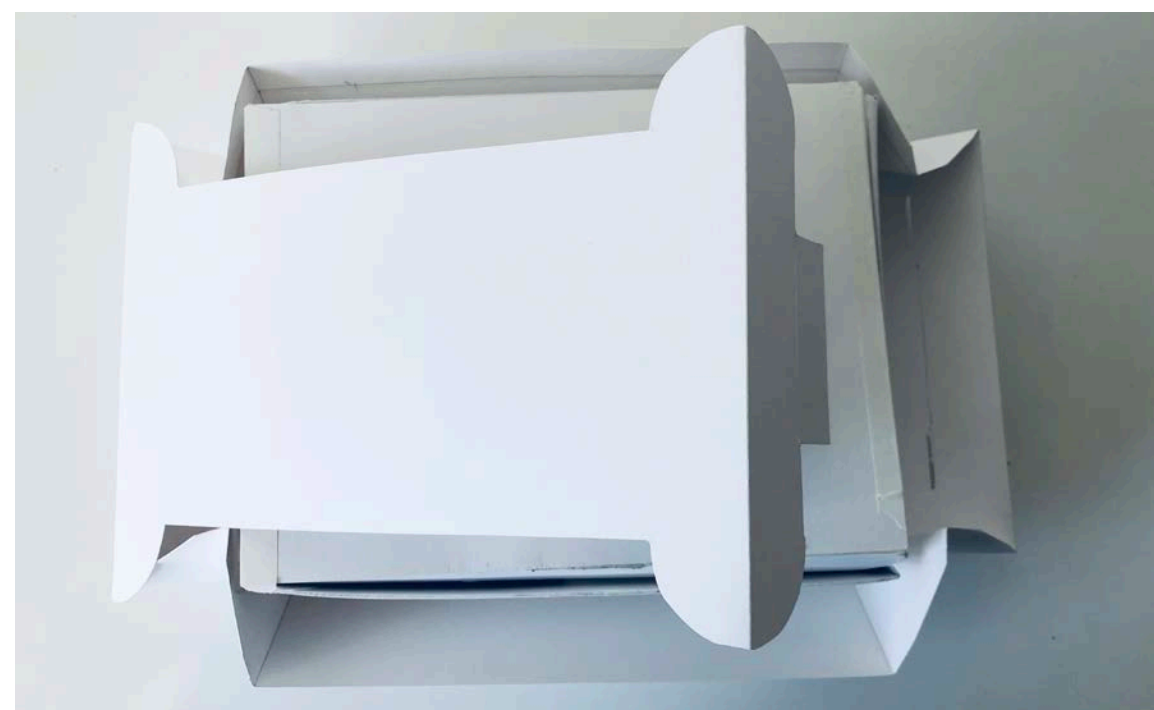

*Super Kit (outer & inner carton)*

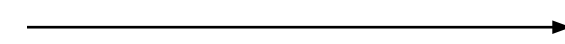

Merged two cartons into one for efficiency

## Phase 5

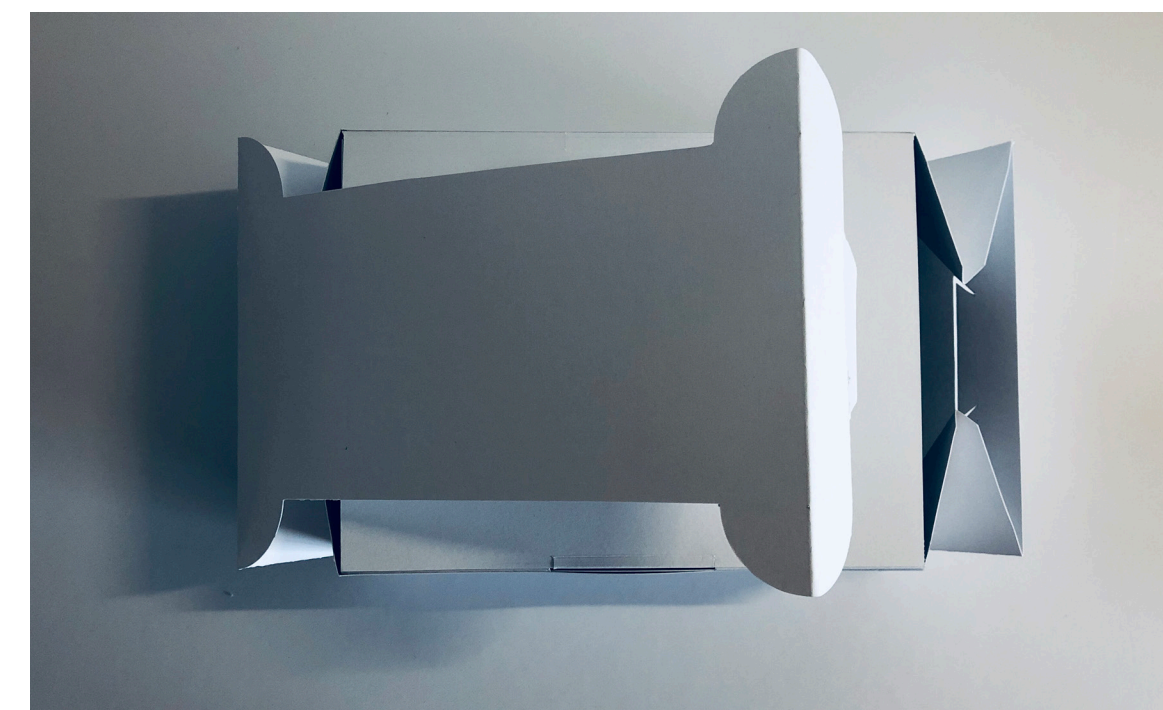

*Super Kit (partially opened)*

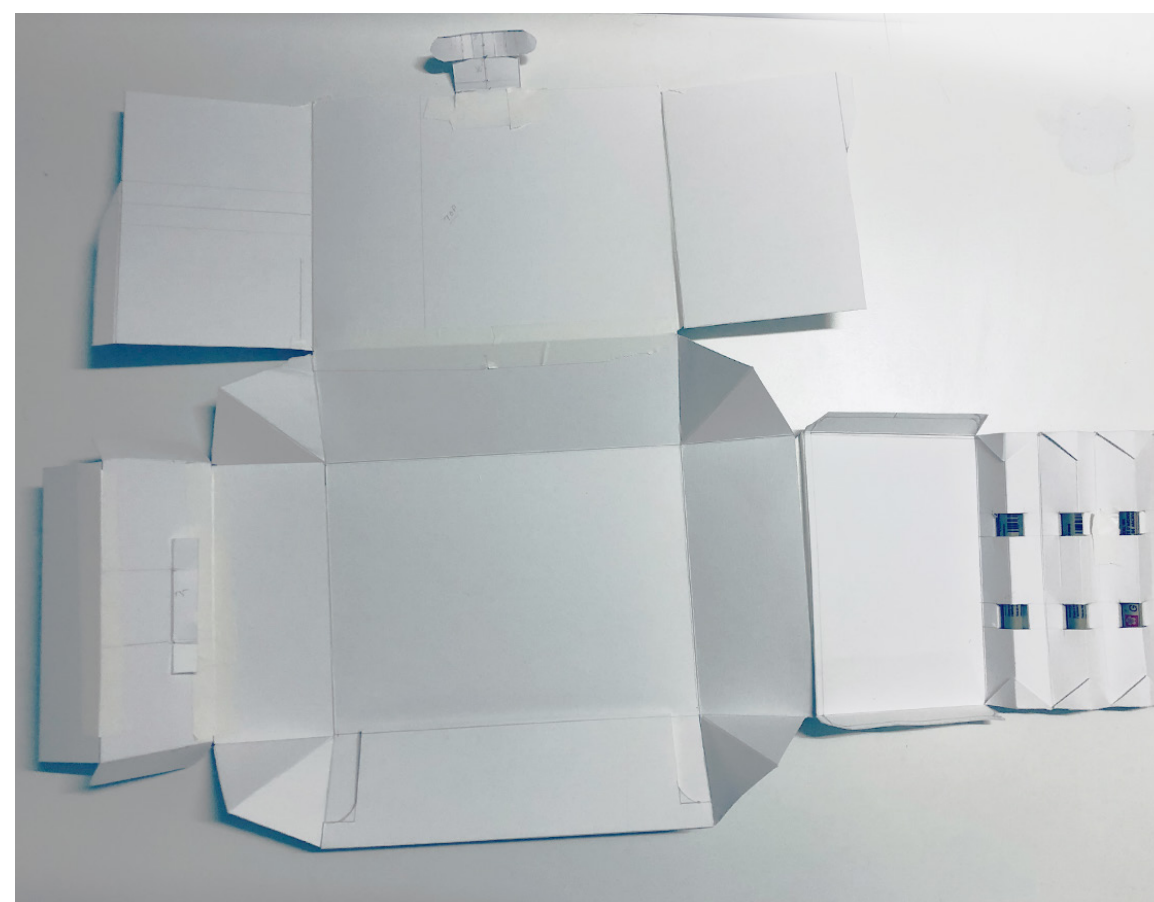

*Super Kit (inner carton)*

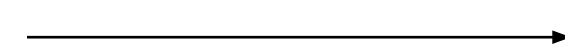

Removed the marker holder & the card wallet. Card wallet became an independent structure

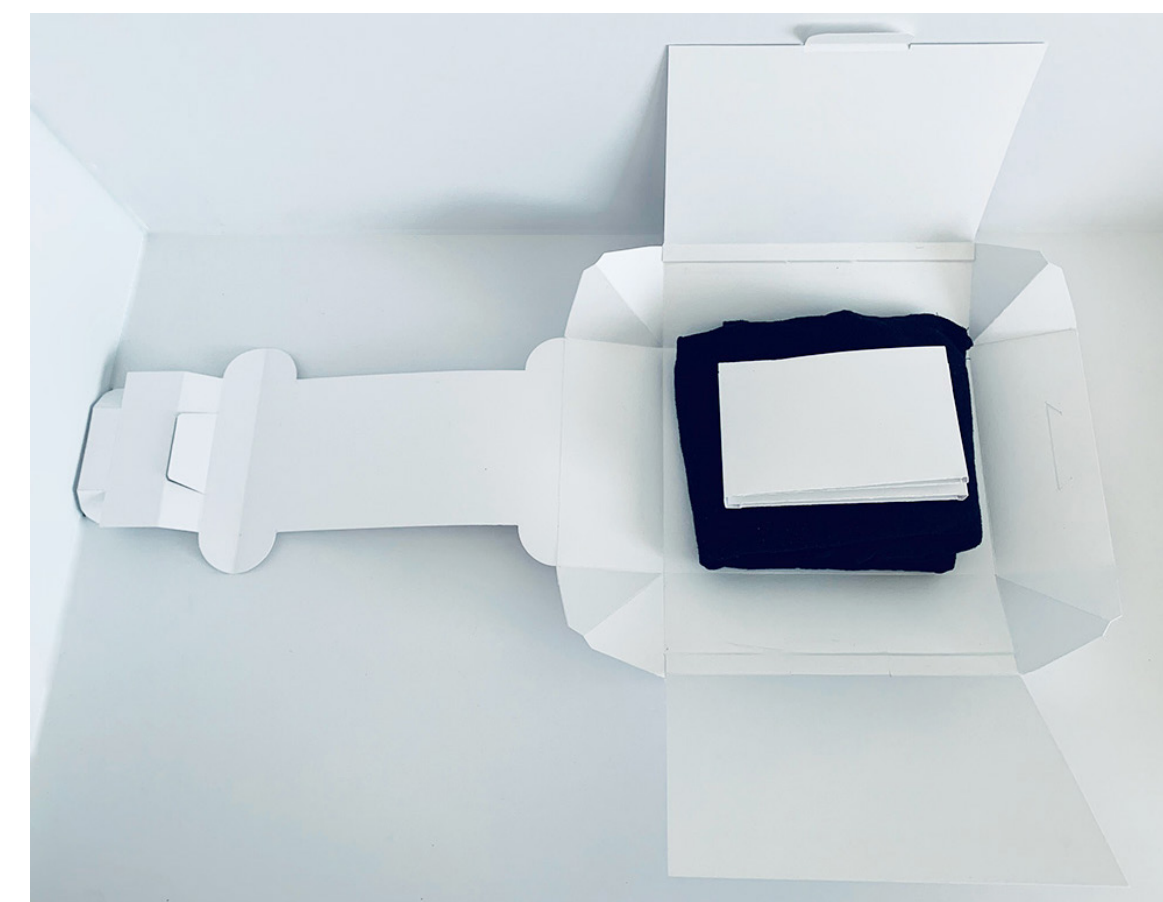

*Super Kit (fully opened)*

# THE SUPER QS (conversation cards) STRUCTURAL PROCESS

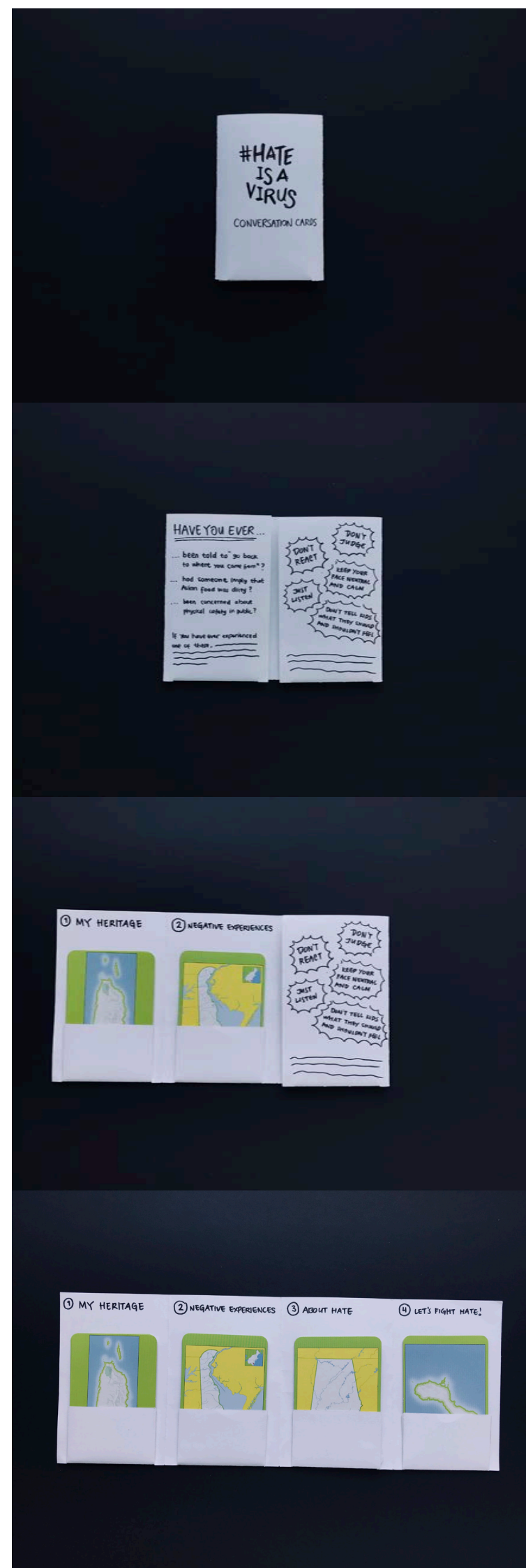

Inspiration: a wallet structure with pockets to hold the cards by topic

Changed the orientation from vertical to horizontal in order to follow the kit's format

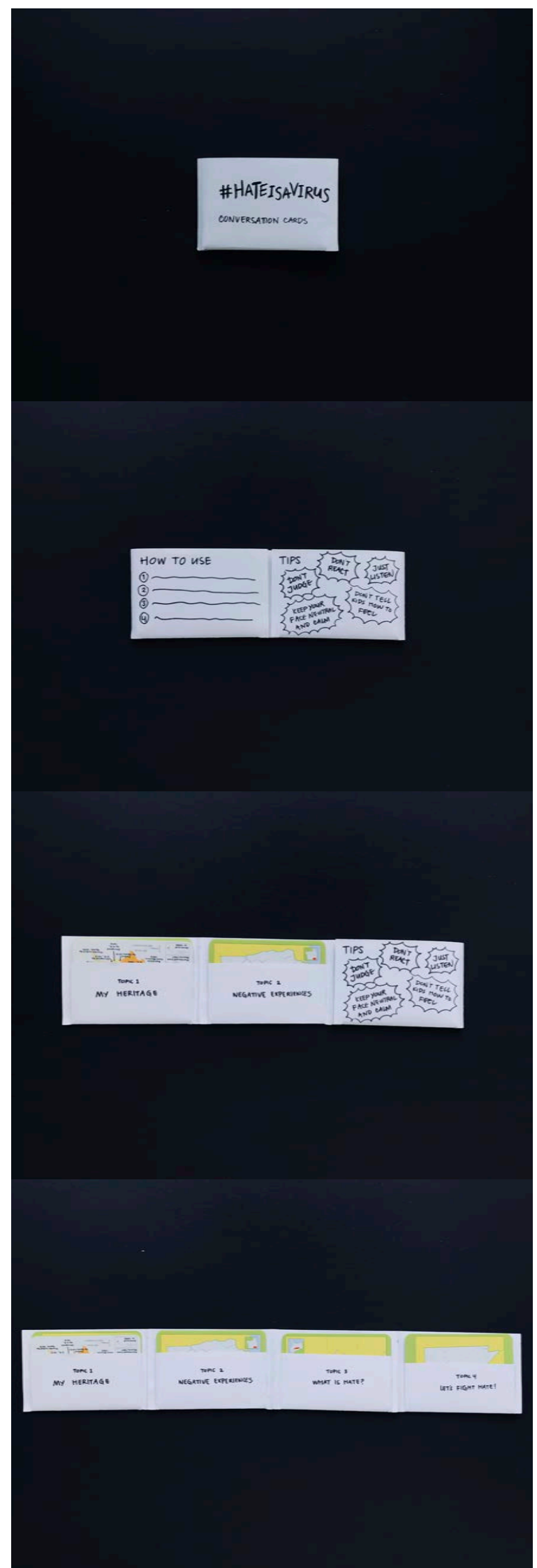

Defined the thickness of the wallet and added a tongue lock to secure the cards

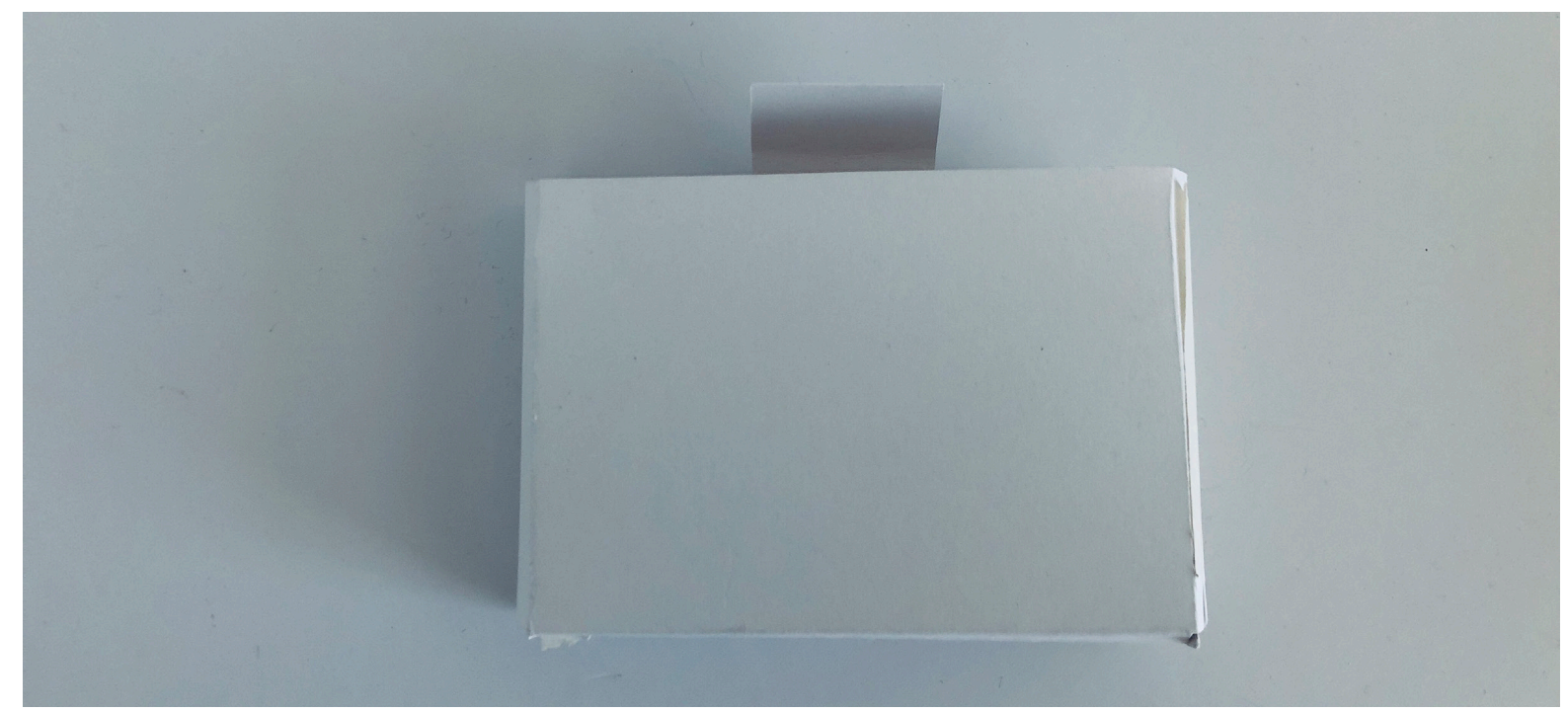

# GRAPHIC PROCESS

## Phase 1

Initial moodboards

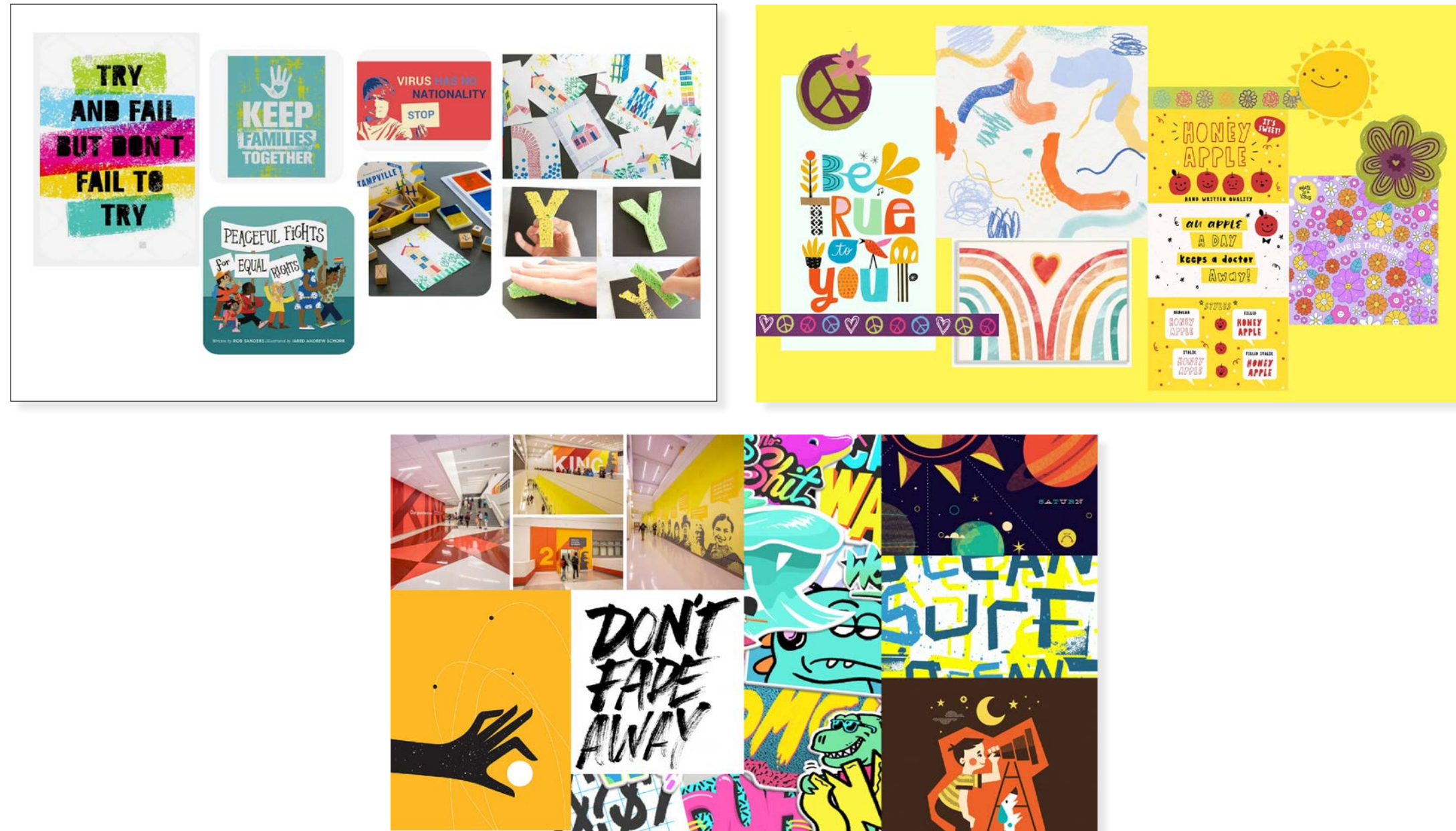

Graphic exploration



## Phase 2

Research on existing branding and advertising

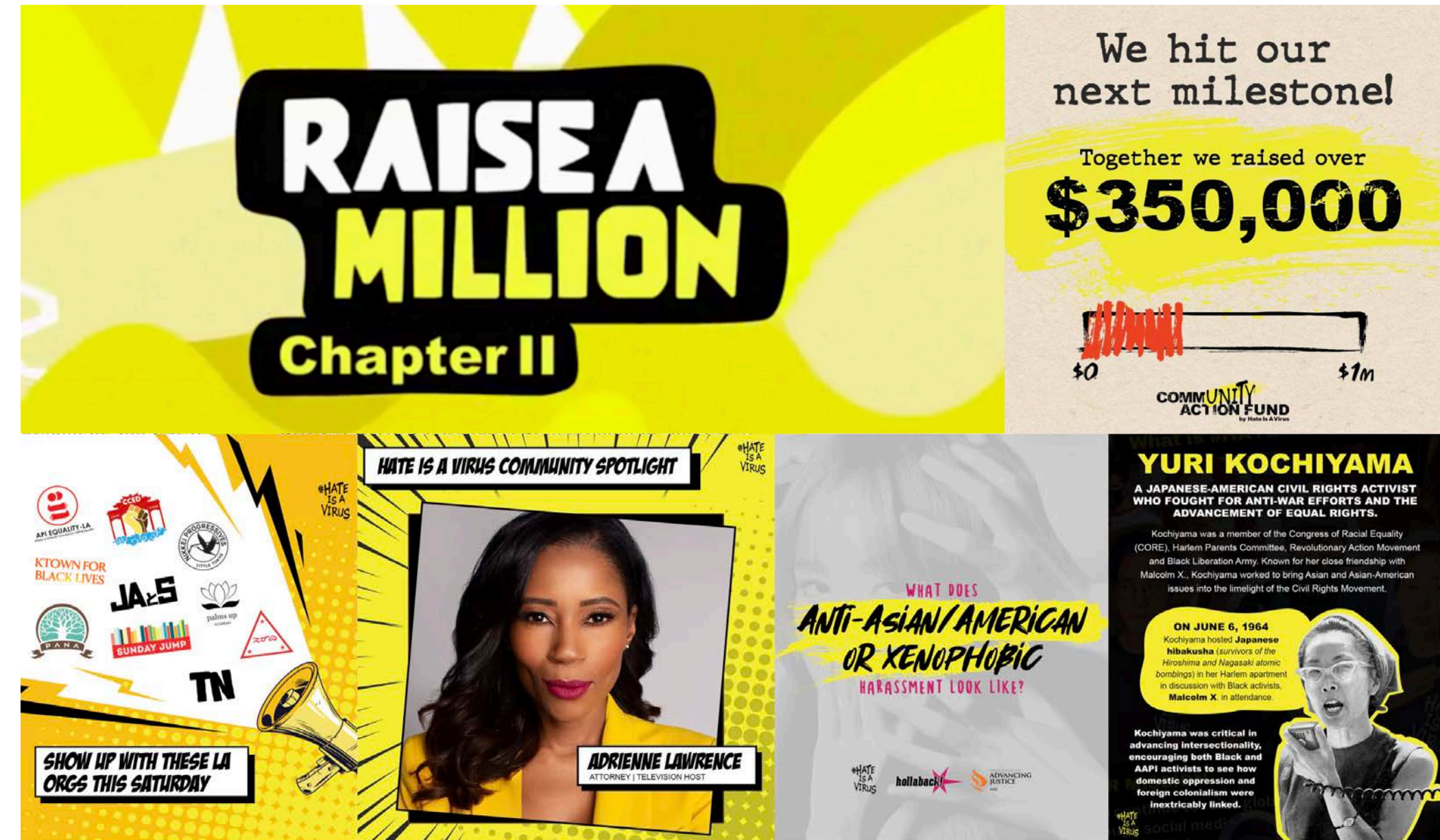

Graphic development



# GRAPHIC PROCESS (continued)

## Phase 3

Final moodboard



Final direction



**TECHNICAL**

# PROTOTYPE

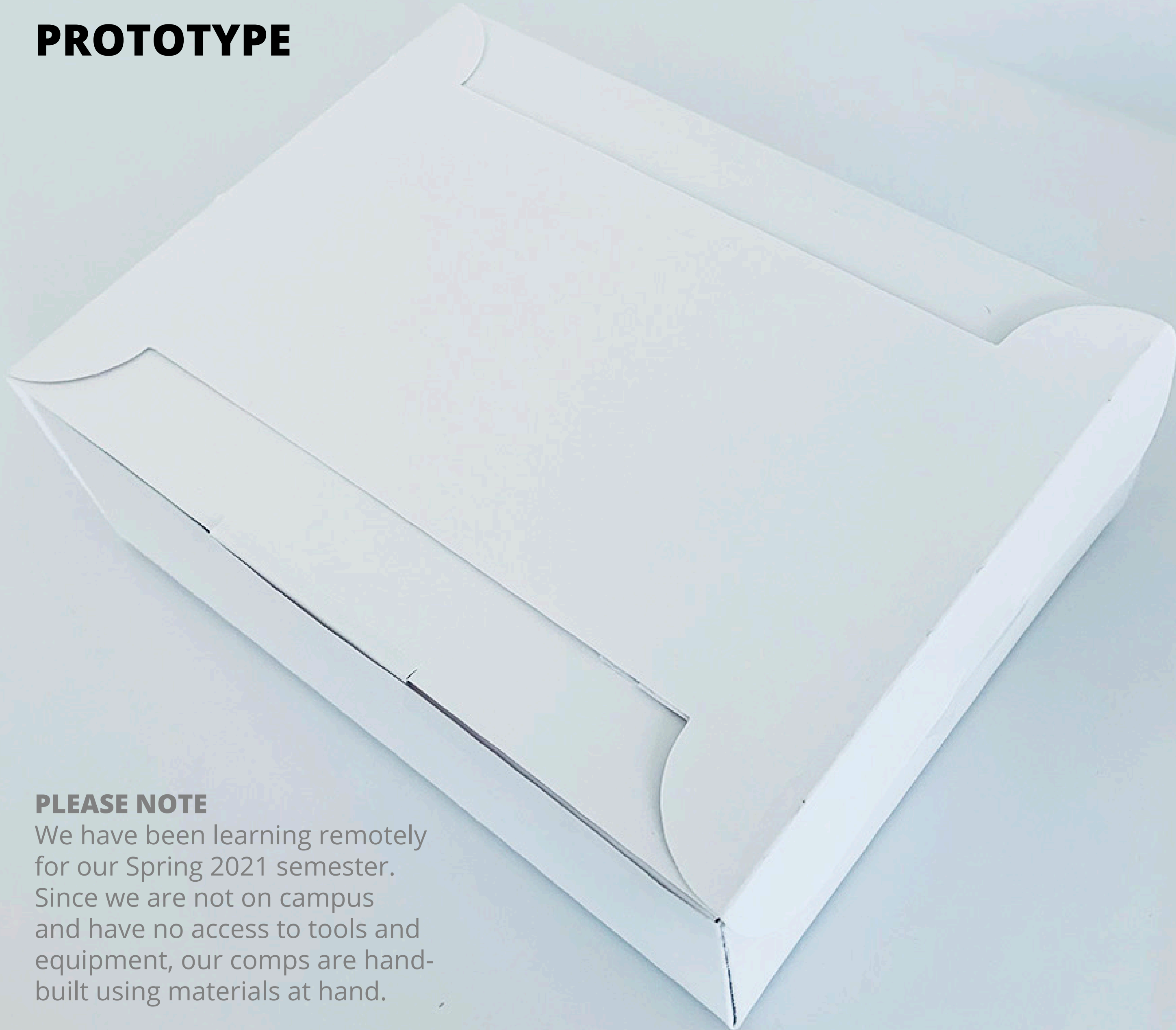

## PLEASE NOTE

We have been learning remotely for our Spring 2021 semester. Since we are not on campus and have no access to tools and equipment, our comps are hand-built using materials at hand.



# PROTOTYPE (continued)

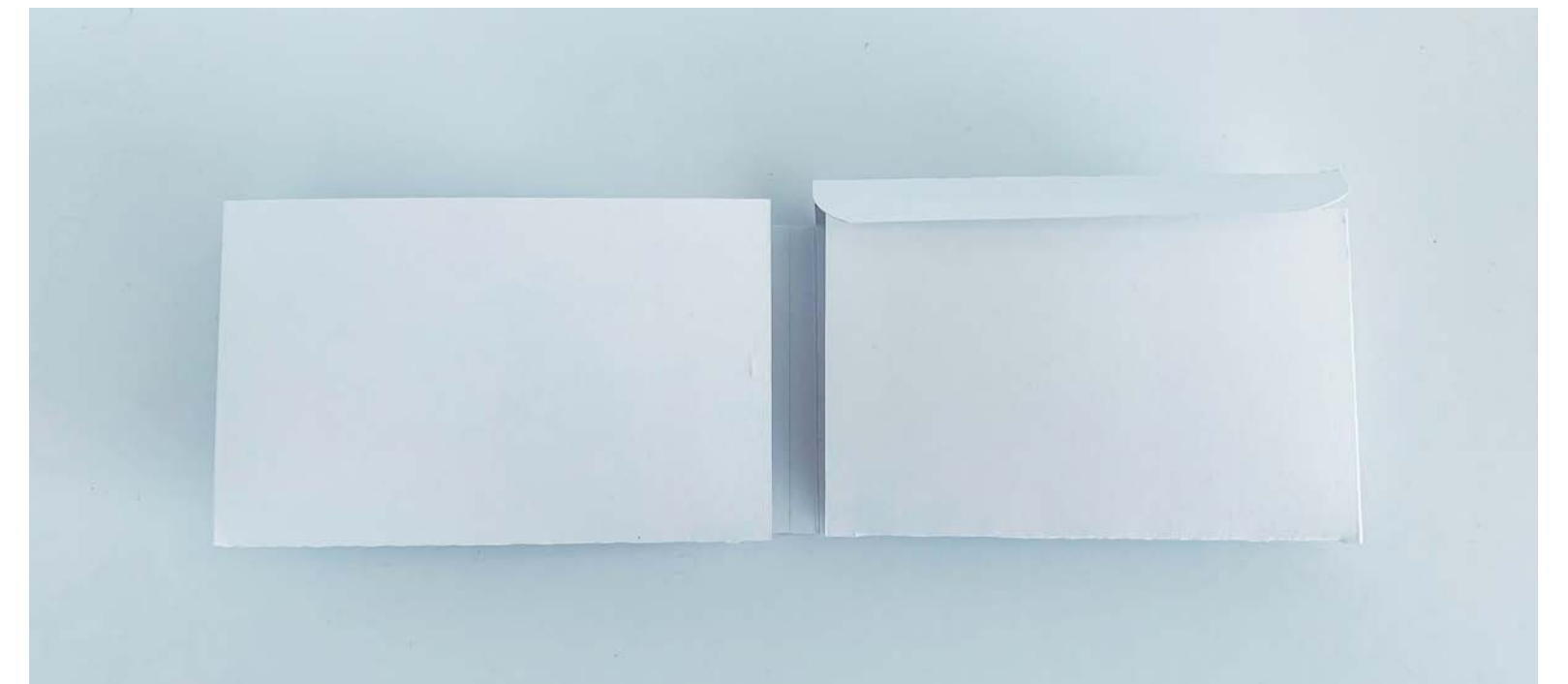
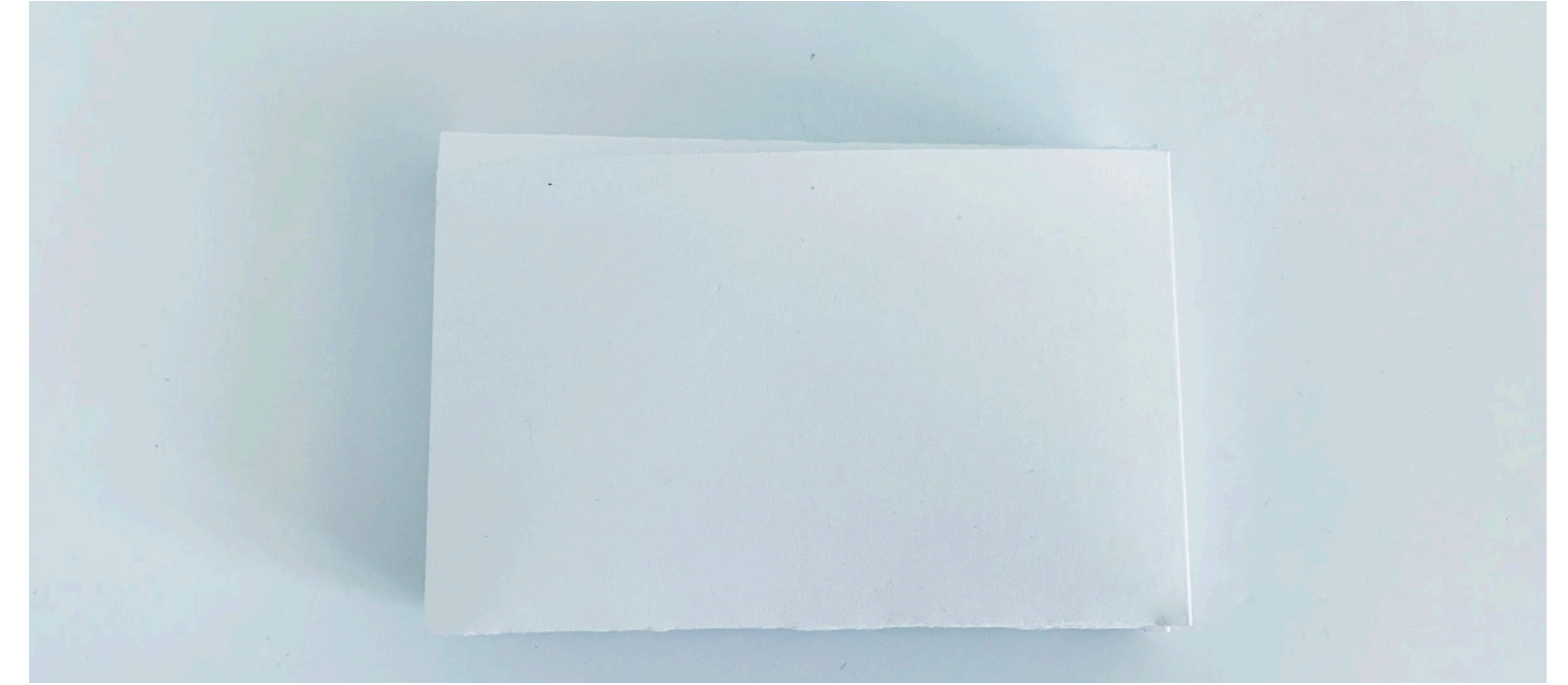

# DIELINES

## The Super Shield

Trim line

Fold line

Perforation

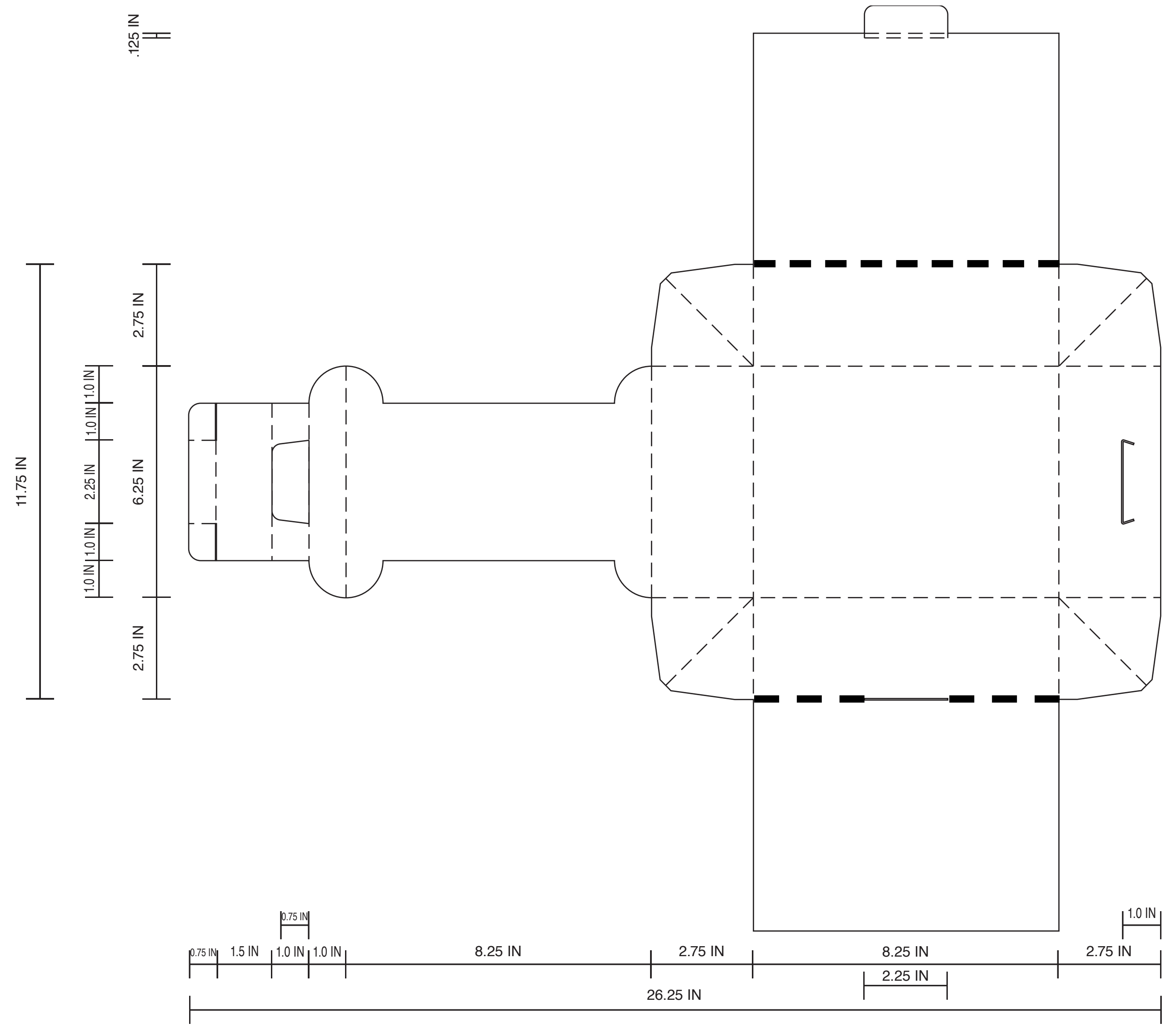

# DIELINES (continued)

## The Super Qs (conversation cards)

\_\_\_\_\_ Trim line

----- Fold line

//////////////////// Glue area

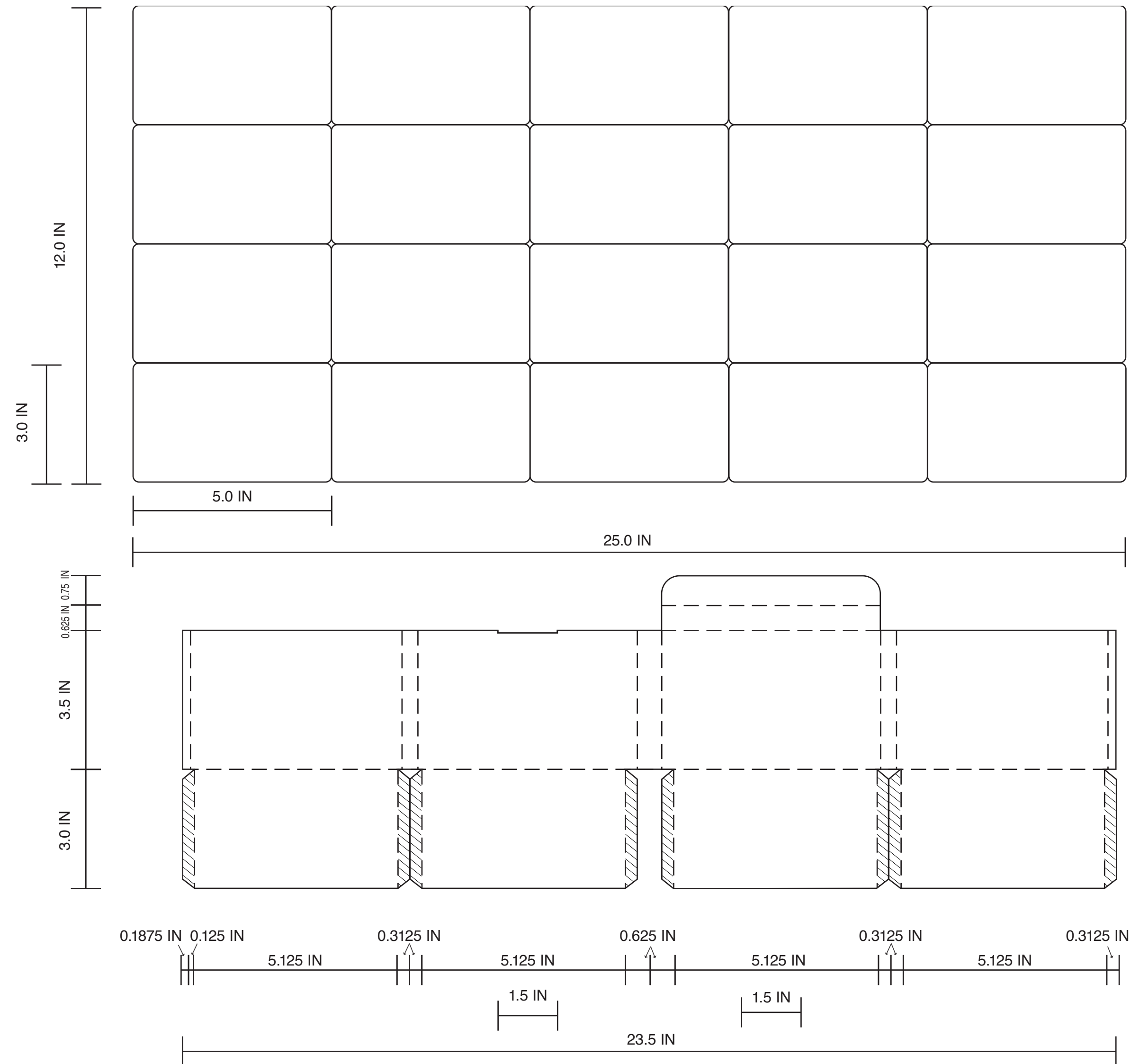

# DIELINES (continued)

Nesting of dielines and double-sided printing (mirrored on long edge) allow one set of the Super Kit to be printed on a 28"x40" sheet.

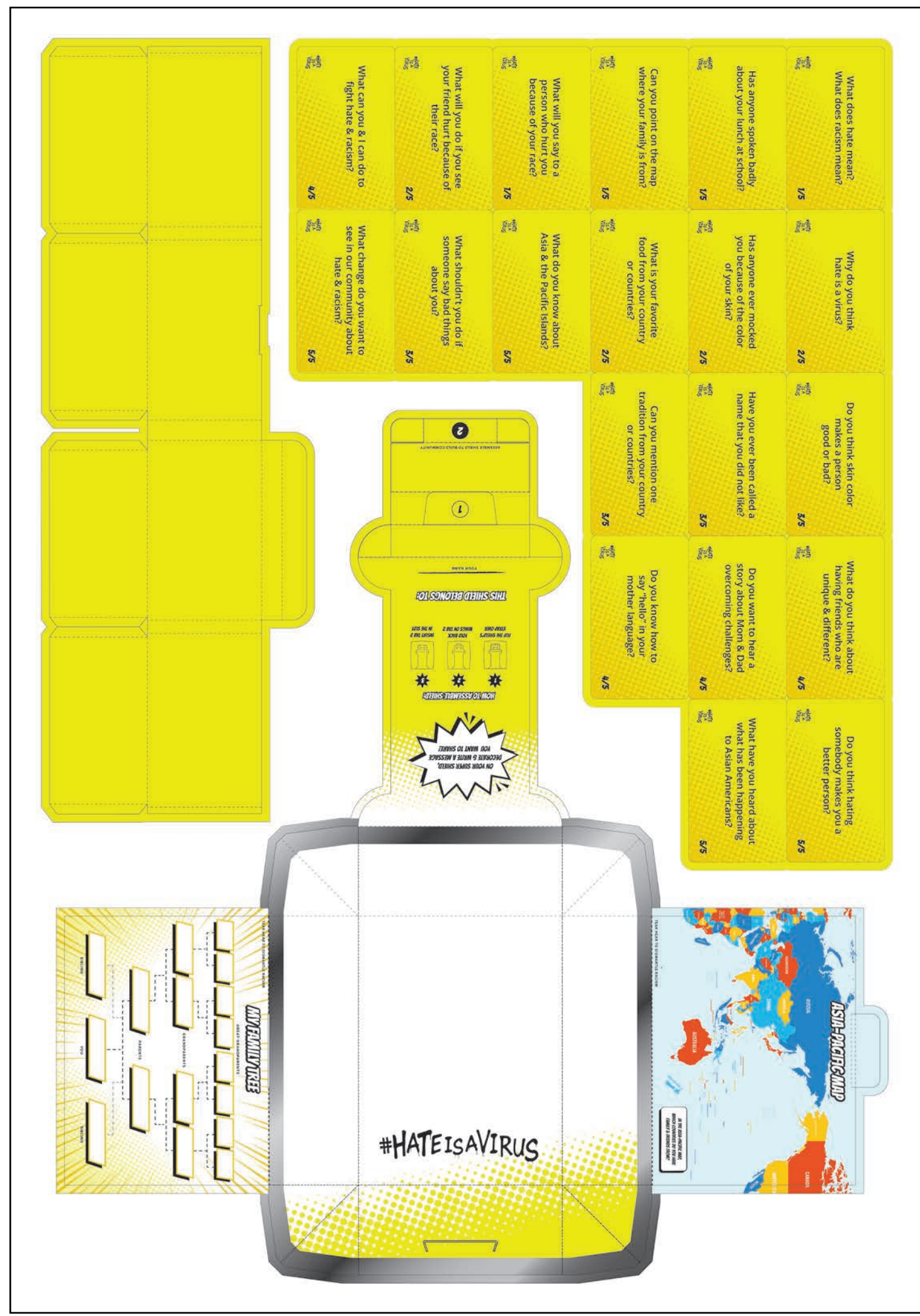

Front

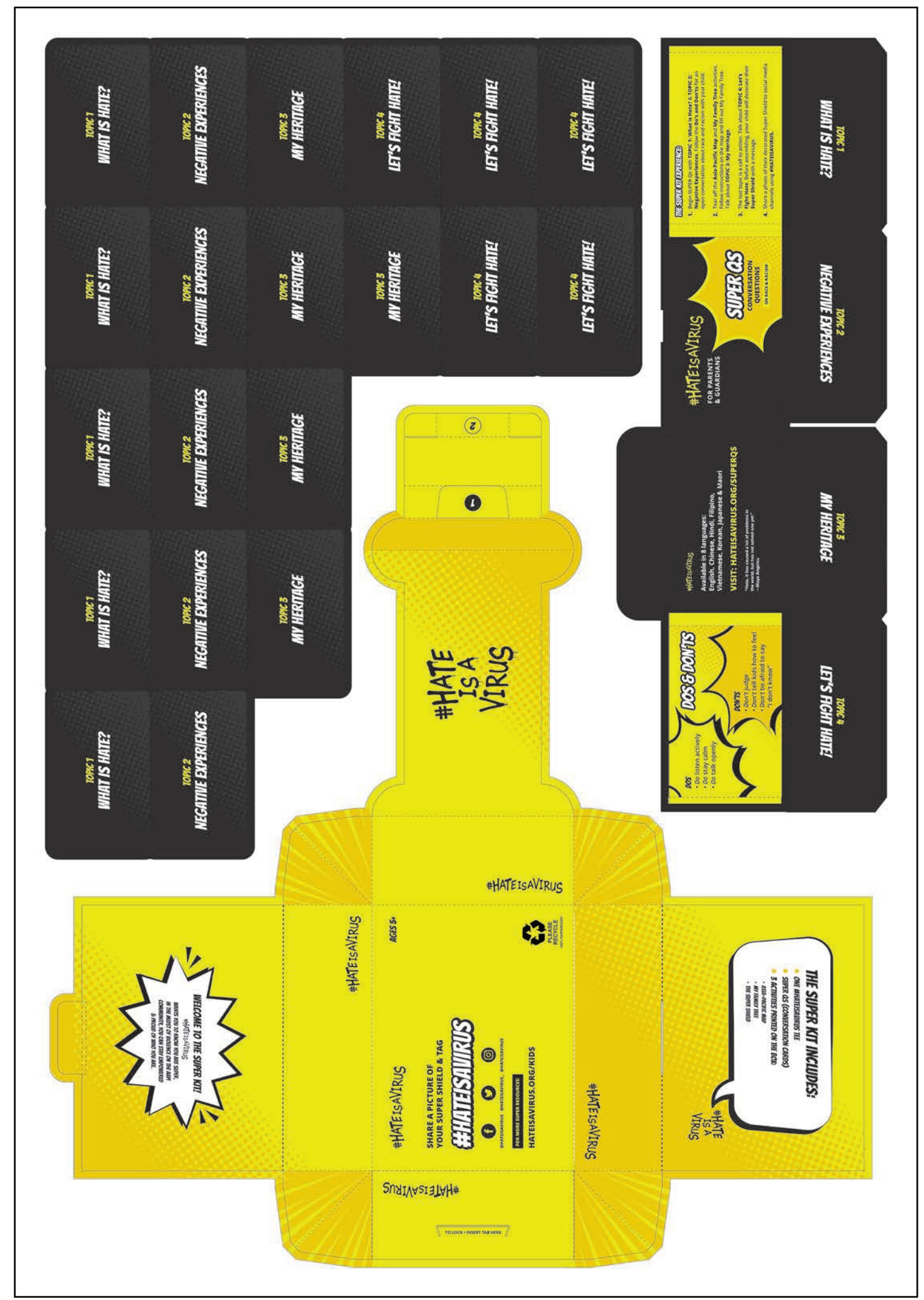

Back

# PLAN FOR SHIPPING & RECEIVING



Guardians request the Super Kit from the Hate Is A Virus' website

Products are supplied by Hate Is A Virus and structures are manufactured

The Super Kits are fulfilled at the fulfillment centers

The Super Kits are transported in corrugated shippers to community centers

Children and guardians pick up the Super Kits at their chosen community centers

**1 shipper = 16 Super Kits**

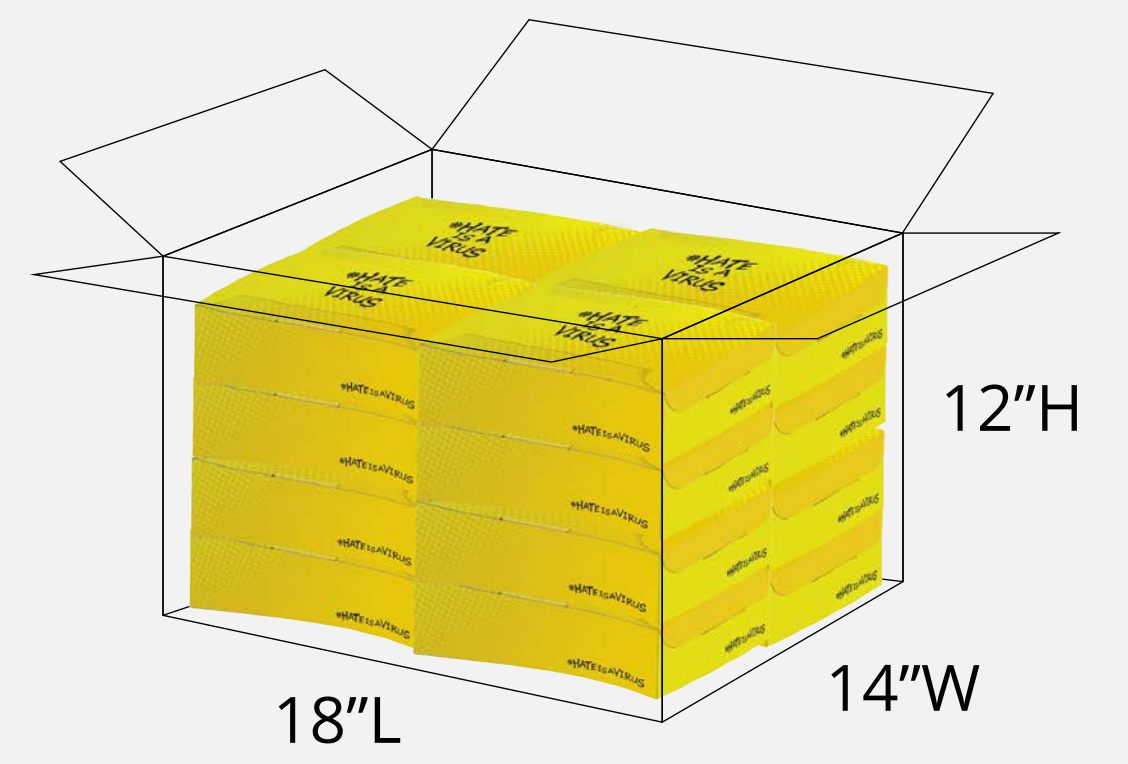

# **BRAND ACTIVATION**

# IN THE HOME

**TOPIC 1**  
**WHAT IS HATE?**

Have you ever been called a name that you did not like?

#HATE IS A VIRUS

3/5

**TOPIC 1**  
**WHAT IS HATE?**

**DOS & DON'TS**

**DOS**

- Do listen actively
- Do stay calm
- Do talk openly

**DON'TS**

- Don't judge
- Don't tell kids how to feel
- Don't be afraid to say "I don't know"

**THE SUPER KIT EXPERIENCE:**

Begin SUPER Qs with **TOPIC 1: What is Hate?** & **TOPIC 2: Negative Experiences**. Follow the **Do's and Don'ts** for an open conversation about race and racism with your child.

Tear off the **Asia-Pacific Map** and **My Family Tree** activities. Follow instructions on the map and fill out My Family Tree. Talk about **TOPIC 3: My Heritage**.

The last topic is a call to action. Talk about **TOPIC 4: Let's Fight Hate**. Before assembling, your child will decorate their **Super Shield** with a message.

Share a photo of their decorated Super Shield to social media channels using **#HATEISAVIRUS**.



**TOPIC 4**  
**LET'S FIGHT HATE!**

What change do you want to see in our community about hate & racism?

#HATE IS A VIRUS

5/5

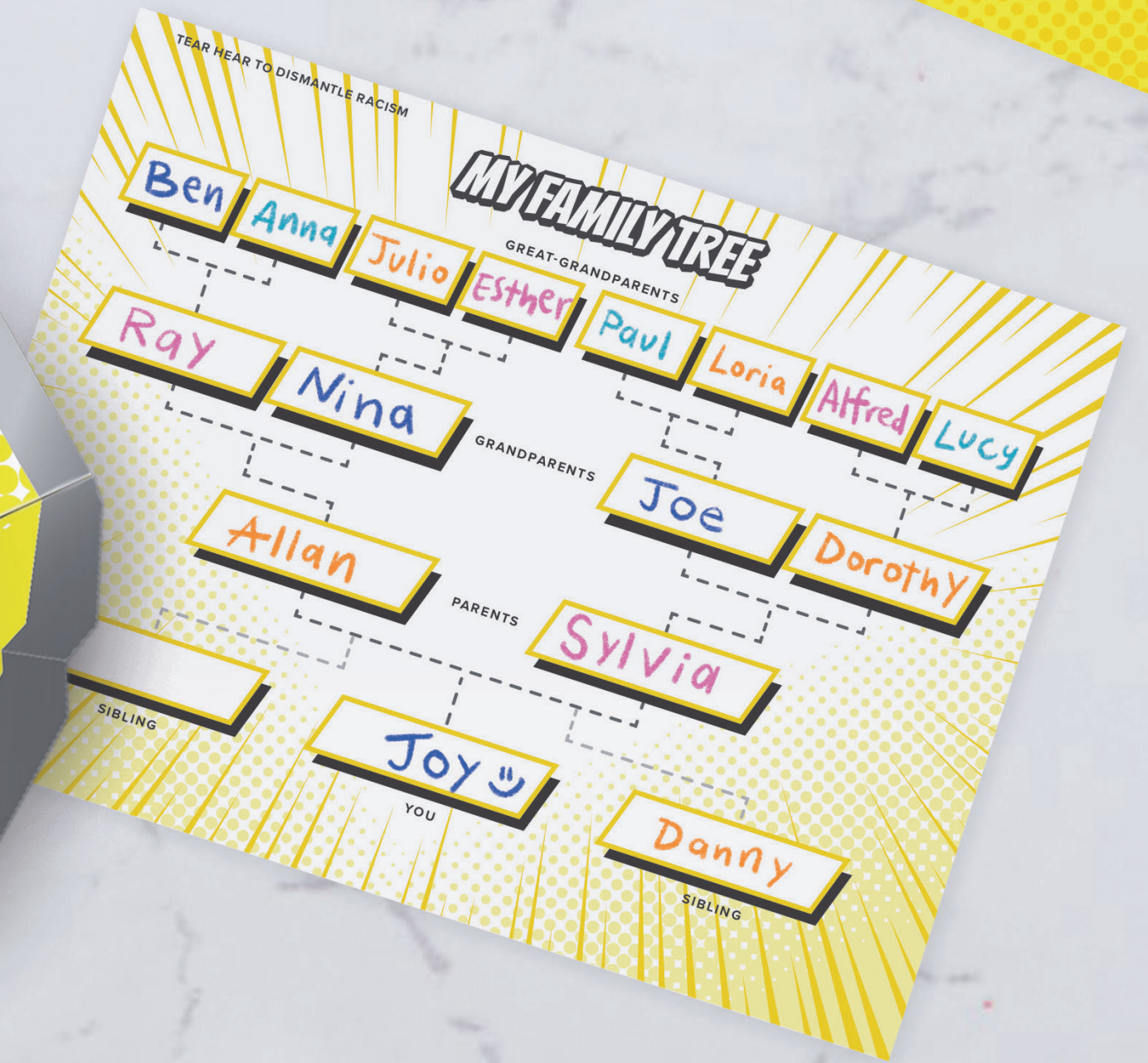



# ONLINE EXPERIENCE

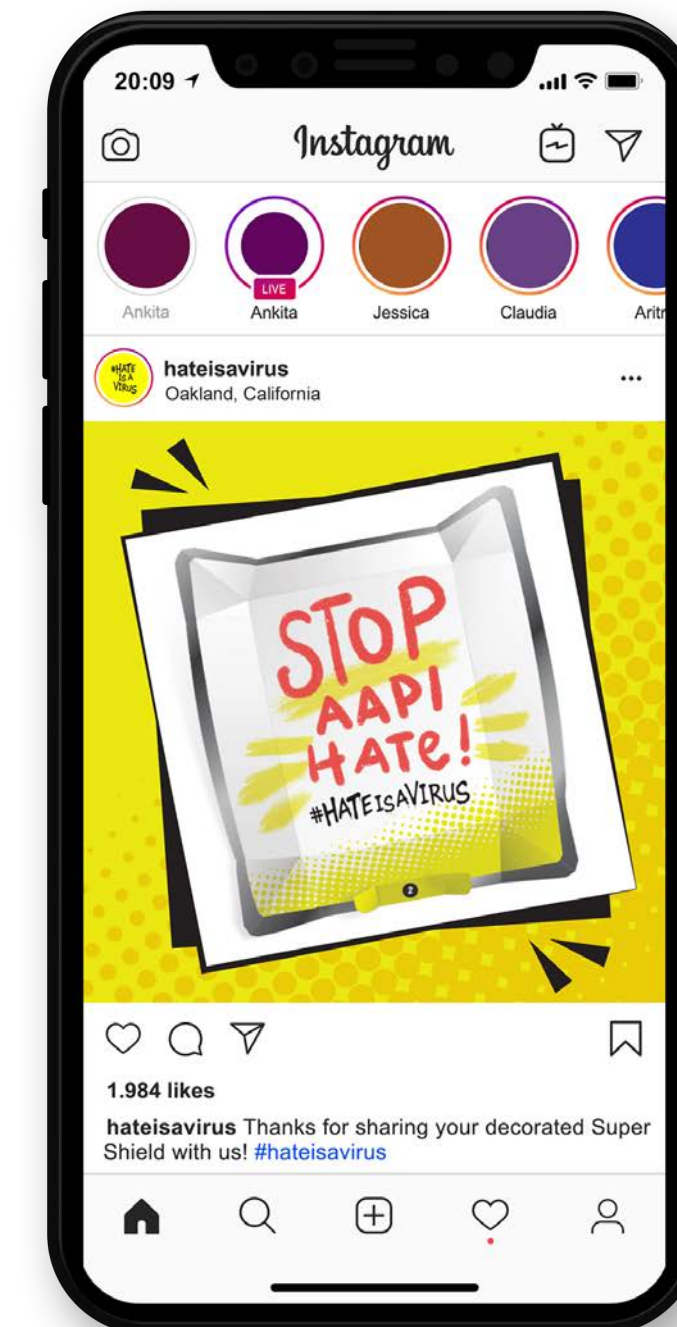
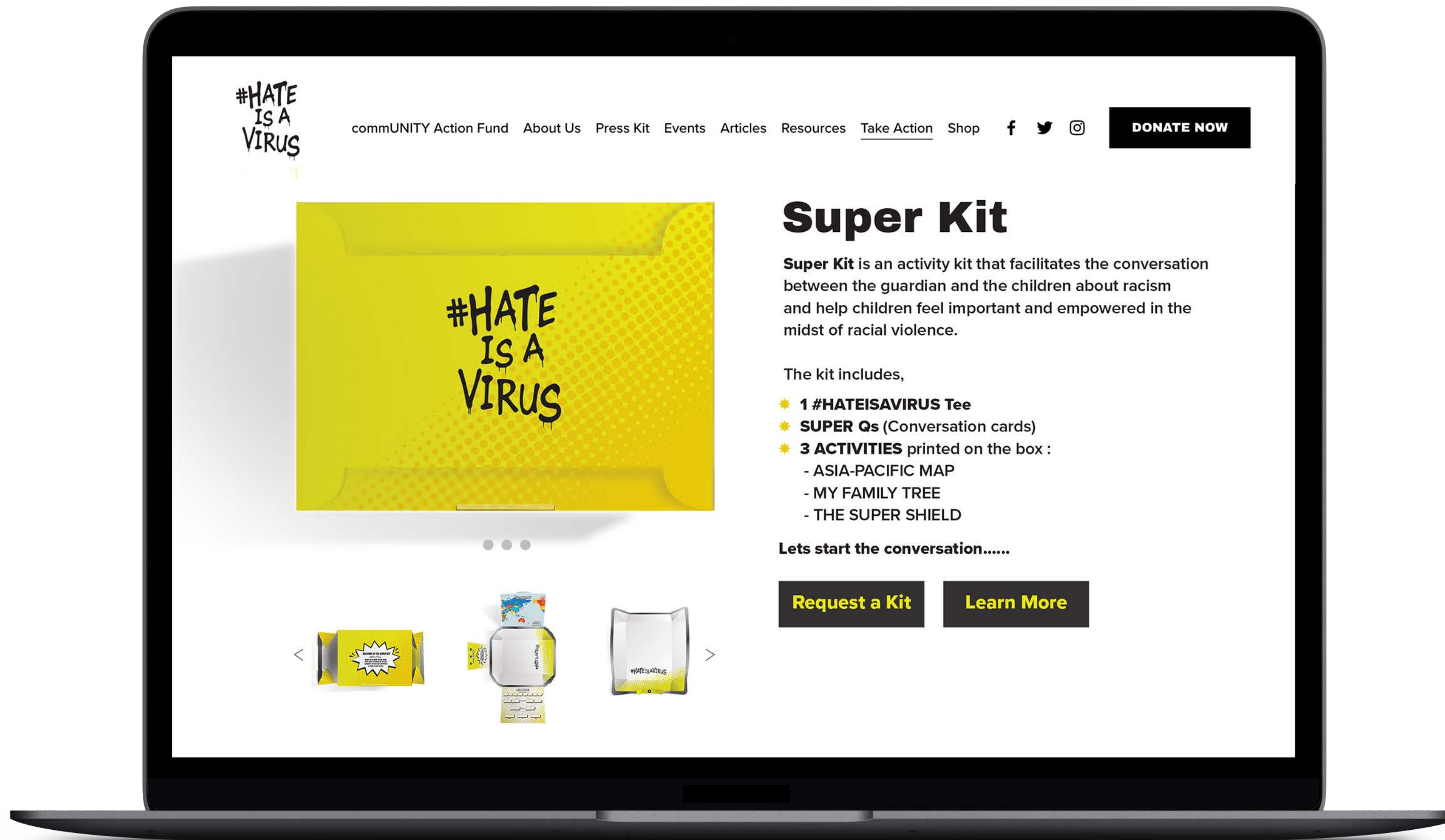

# UNBOXING VIDEO

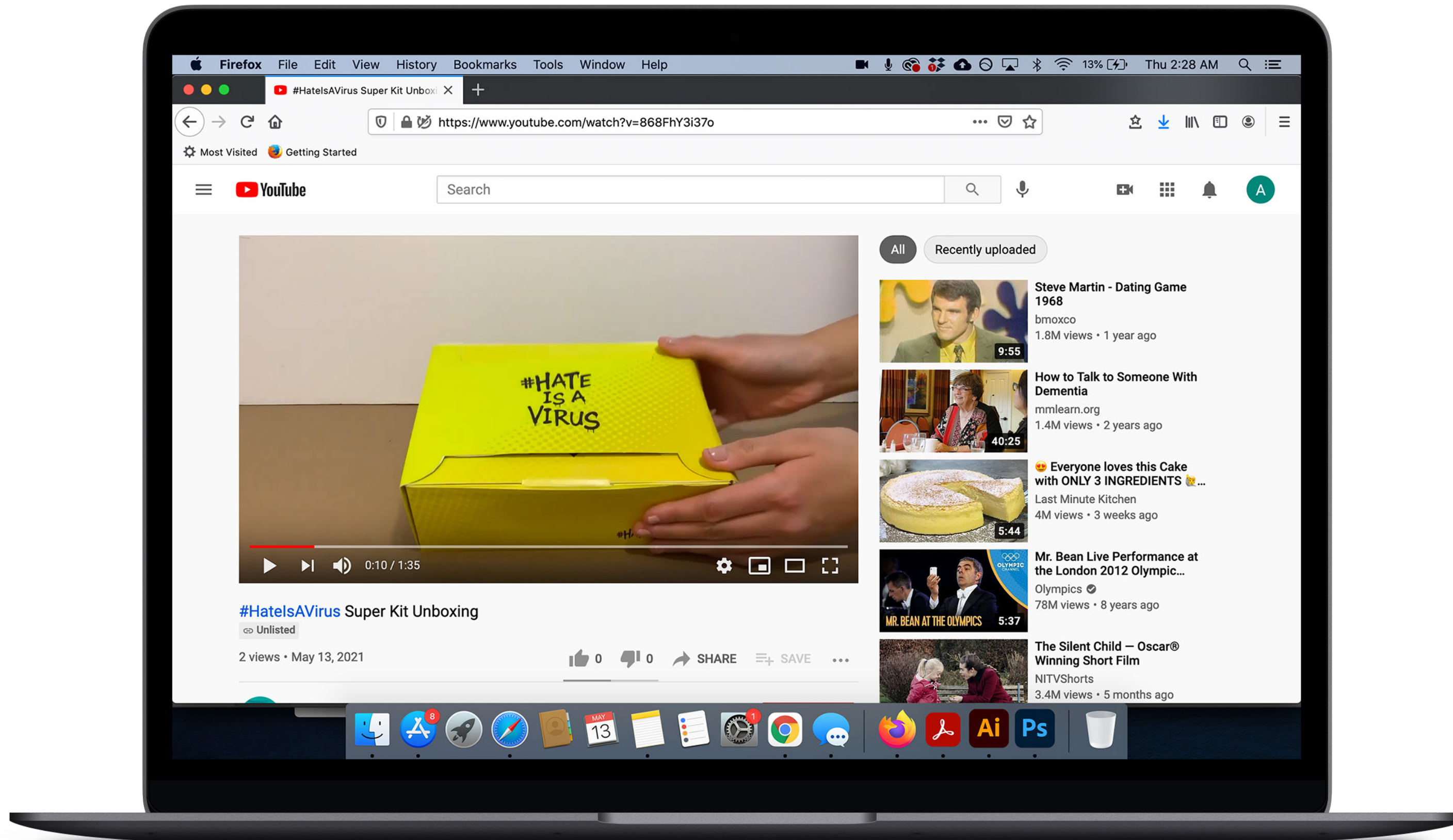

or

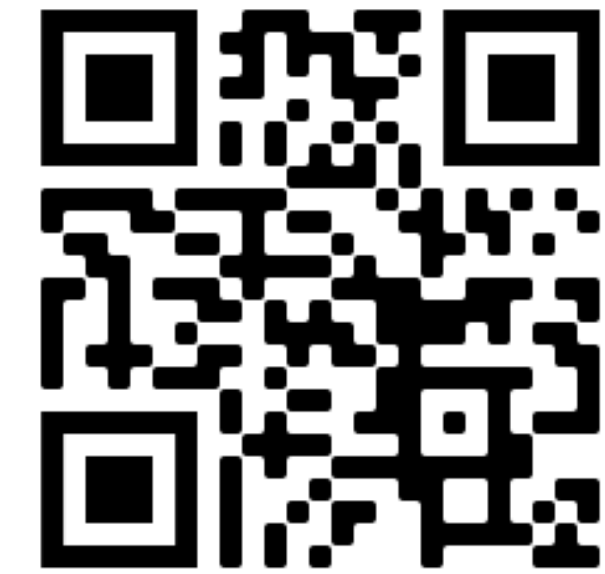

Scan to watch

Click the link to watch  
<https://youtu.be/868FhY3i37o>

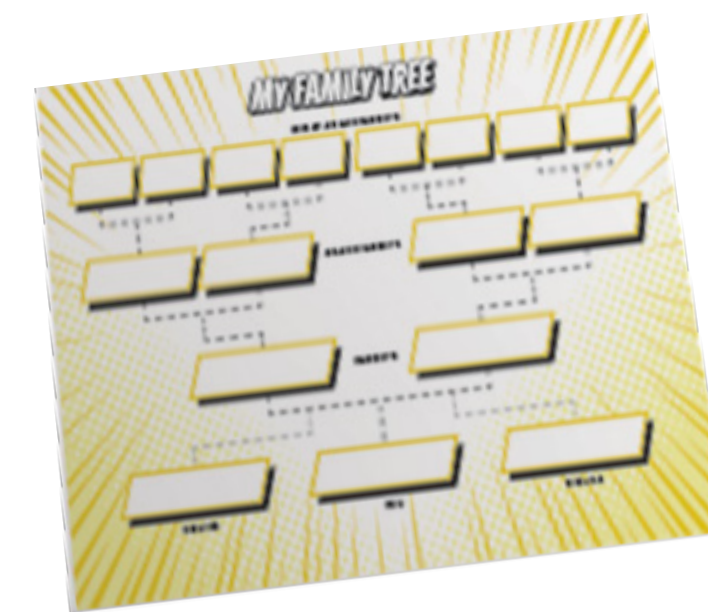

# THANK YOU

Dhanyavad | Terima Kasih | Salamats | Saina Ma'ãse



# CITATIONS



<https://hateisavirus.org/>



<https://www.pexels.com/photo/positive-mother-with-daughter-and-son-watching-cartoon-on-tv-4474011/>



<https://elements.envato.com/portrait-image-of-young-asian-child-brother-wearin-S6AZTMA>



<https://www.asianmhc.org/>



<https://weareuprisers.com/products/hateisavirus-black-tee>



<https://www.pexels.com/photo/brown-horse-running-on-water-6215907/>



<https://elements.envato.com/superhero-kids-on-a-black-background-ZGLSJML>



<https://www.advancingjustice-aajc.org/>



[https://www.instagram.com/p/CIWEs4mgb\\_b/](https://www.instagram.com/p/CIWEs4mgb_b/)

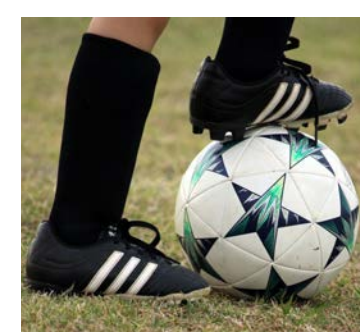

<https://unsplash.com/photos/AzDHa9F9uBY>



<https://www.pexels.com/photo/person-people-woman-art-7105601/>



<https://www.amazon.com/Little-Travelers-Library-Adventures-Languages/dp/1454920068>



<https://www.dreamstime.com/world-map-asia-australia-pacific-ocean-centered-bright-color-scheme-high-detailed-political-map-world-country-world-image199021385>



<https://www.pexels.com/photo/yellow-shovel-half-buried-on-sand-near-the-ocean-296357/>



<https://www.aalead.org/>



<https://www.inkidzco.com/>

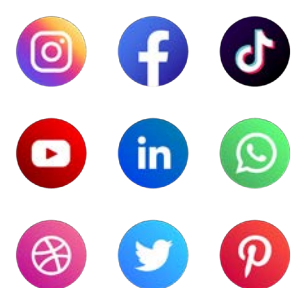

<https://www.vecteezy.com/vector-art/1972883-set-of-social-media-logo>



<https://unsplash.com/photos/RSgwLqIWH8w>



<https://stopaapihate.org/>



<https://www.byusbox.com/>

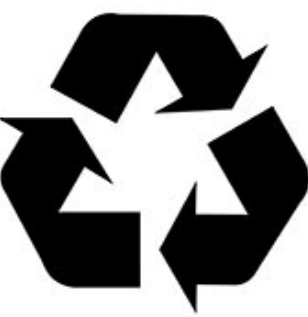

<https://www.recycling.com/downloads/recycling-symbol/>



<https://www.pexels.com/photo/composition-of-ripe-fruits-on-white-table-4230662/>



<https://www.asianhalloffame.org/>

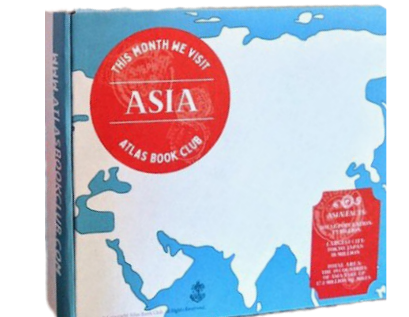

<https://www.atlasbookclub.com/>

# CITATIONS (continued)

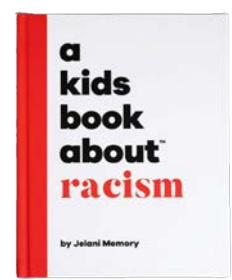

<https://akidsbookabout.com/>



<https://artfulparent.com/stampville-architecture-stamps/>



<https://www.pinterest.com/pin/529806343670142308/>



<https://www.designspiration.com/save/2158581791837/>



<https://pixabay.com/vectors/felt-tip-felt-pen-marker-black-154473/>



<https://artfulparent.com/stampville-architecture-stamps/>



[https://www.instagram.com/p/CGaUdxBAmt\\_/](https://www.instagram.com/p/CGaUdxBAmt_/)



<https://www.designspiration.com/save/395905243677/>



<https://www.dreamstime.com/stock-illustration-try-fail-do-not-fail-t-try-bright-motivation-quote-creative-grunge-vector-typography-poster-concept-image88222170>



<https://www.woojr.com/y-is-for-yellow-sponge-stamping-craft/>



<https://www.aiaga.org/design-award/martin-luther-king-jr-middle-school/>



<https://www.designspiration.com/save/85944077556/>

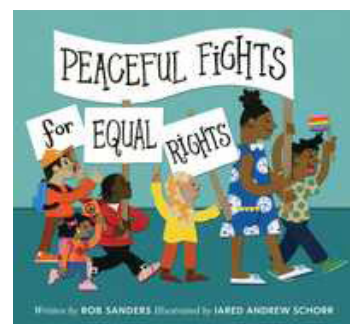

<https://dusoleil.leslibraires.ca/livres/peaceful-fights-for-equal-rights-rob-sanders-9781534429437.html>



<https://www.pinterest.com/pin/563864815844156863/>



<https://www.designspiration.com/save/56146833703/>



<https://www.facebook.com/hateisavirus/photos/273049970990875>



[https://www.zazzle.com/keep\\_families\\_together\\_poster-228642555840437923](https://www.zazzle.com/keep_families_together_poster-228642555840437923)



<https://www.etsy.com/listing/637312351/sun-sunshine-clip-art-graphics-hand?epik=dj0yJnU9RzhtSm9xMTdMTWxleExnbXUyaG9YVHN3aUdwSG9Ddl8mcD0wJm49UEY3T0ZWTGY0MUFQN3J5SDZiYXV3QSZ0PUFBQUFBROnVVF>



<https://www.designspiration.com/save/2127730977/>



<https://www.facebook.com/hateisavirus/photos/281335230162349>



<https://www.adl.org/education/resources/tools-and-strategies/coronavirus-and-infectious-racism-ms-hs>



[https://www.thinkmakeshareblog.com/january-2018-digital-wallpapers/#\\_a5y\\_p=6610897](https://www.thinkmakeshareblog.com/january-2018-digital-wallpapers/#_a5y_p=6610897)

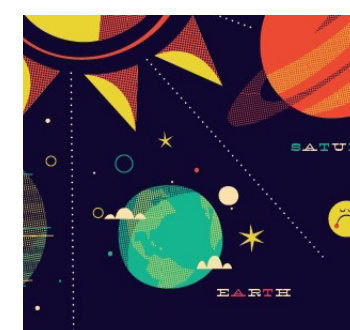

<https://www.designspiration.com/save/35137668170/>



<https://www.facebook.com/hateisavirus/photos/263296738632865>

# CITATIONS (continued)



[https://www.facebook.com/watch/live/?v=382532316213768&ref=watch\\_permalink](https://www.facebook.com/watch/live/?v=382532316213768&ref=watch_permalink)



[www.pexels.com/photo/red-and-yellow-stop-sticker-1749900/](http://www.pexels.com/photo/red-and-yellow-stop-sticker-1749900/)



[https://unsplash.com/photos/odHg\\_WUrZ10](https://unsplash.com/photos/odHg_WUrZ10)



[www.pnghunter.com/png/silver-shield/](http://www.pnghunter.com/png/silver-shield/)



[www.youngjerks.com/Marvel-Comics](http://www.youngjerks.com/Marvel-Comics)



<https://www.dreamstime.com/anti-asian-hate-rally-washington-dc-usa-many-people-gathered-around-mcpherson-square-to-demonstrate-to-demand-stop-asian-hate-image214271591>



[www.buamai.com/image/6423](http://www.buamai.com/image/6423)



<https://elements.envato.com/portrait-of-child-boy-playing-a-football-CNAT88D>

<https://www.pexels.com/>  
<https://pixabay.com/>  
<https://unsplash.com/>  
<https://www.vecteezy.com/>



[www.facebook.com/hateisavirus/photos/pcb.268275971468275/268275854801620/](http://www.facebook.com/hateisavirus/photos/pcb.268275971468275/268275854801620/)



<https://www.pexels.com/photo/calm-woman-with-son-and-daughter-in-face-masks-4472977/>



<https://www.facebook.com/hateisavirus/photos/279427493686456>



<https://www.pexels.com/photo/happy-asian-boy-with-raised-arm-5560485/>



[https://br.freepik.com/vetores-gratis/conjunto-de-baloes-de-fala-em-papel\\_12557730.htm#page=1&query=Baloes%20de%20fala&position=12](https://br.freepik.com/vetores-gratis/conjunto-de-baloes-de-fala-em-papel_12557730.htm#page=1&query=Baloes%20de%20fala&position=12)

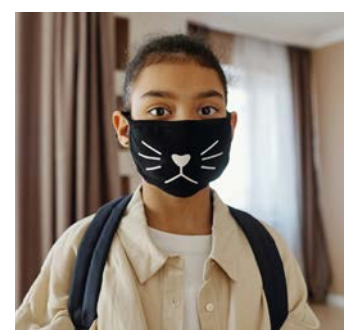

<https://www.pexels.com/photo/little-girl-wearing-a-face-mask-with-a-design-4261260/>